

01/2025

VMA VERLAG  
Cologne /Germany

# EXTRUSION INTERNATIONAL

USA

# Guill

WORLD LEADER IN EXTRUSION TOOLING

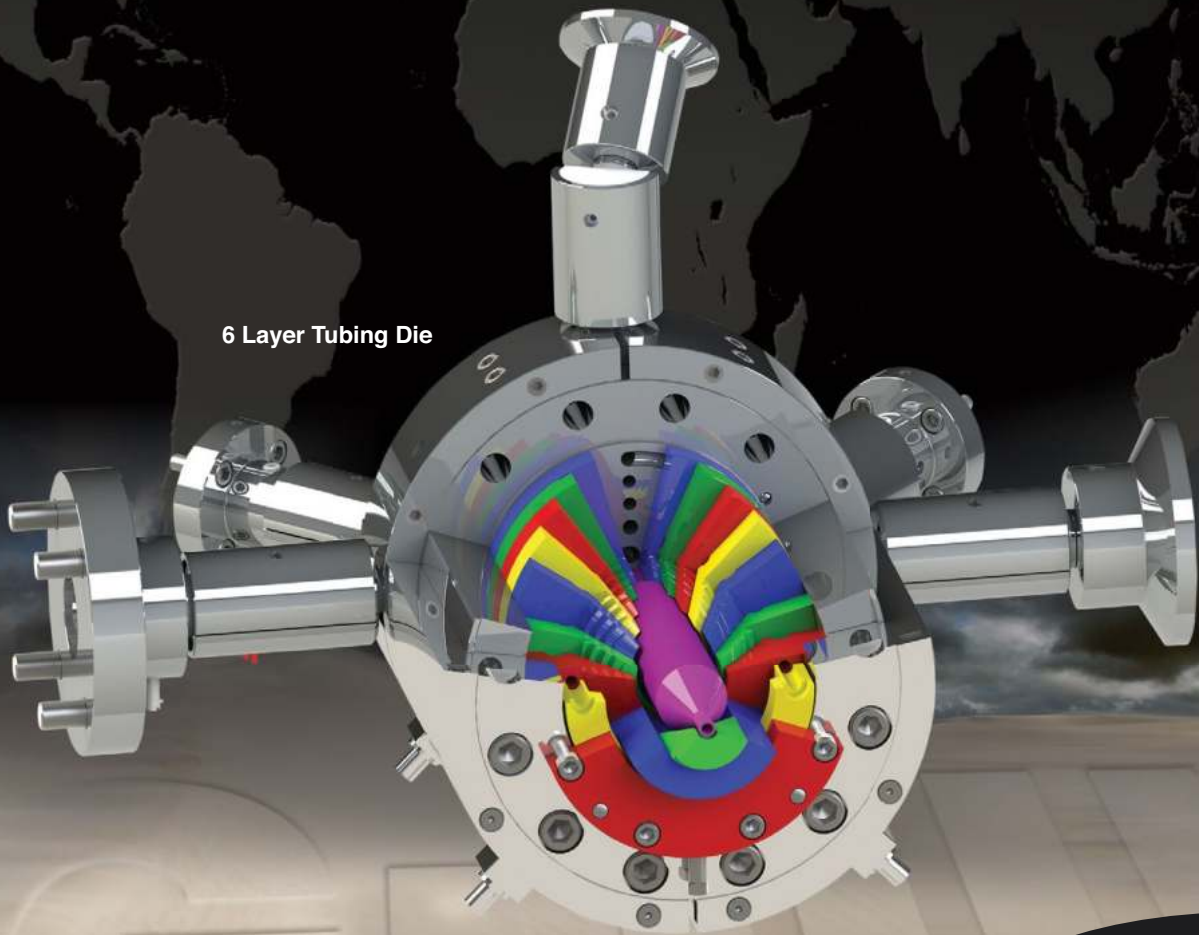

6 Layer Tubing Die

[www.guill.com](http://www.guill.com)

**GUILL**  
Now Offers  
Basket Dies



### Plate Stacking Machine

for automatic depositing of your production plates on transport pallets or trolleys.

Optional available with:

- Additional stacking places
- Spreading device of sheets side by side
- Separation of consecutive panels for simultaneous stacking

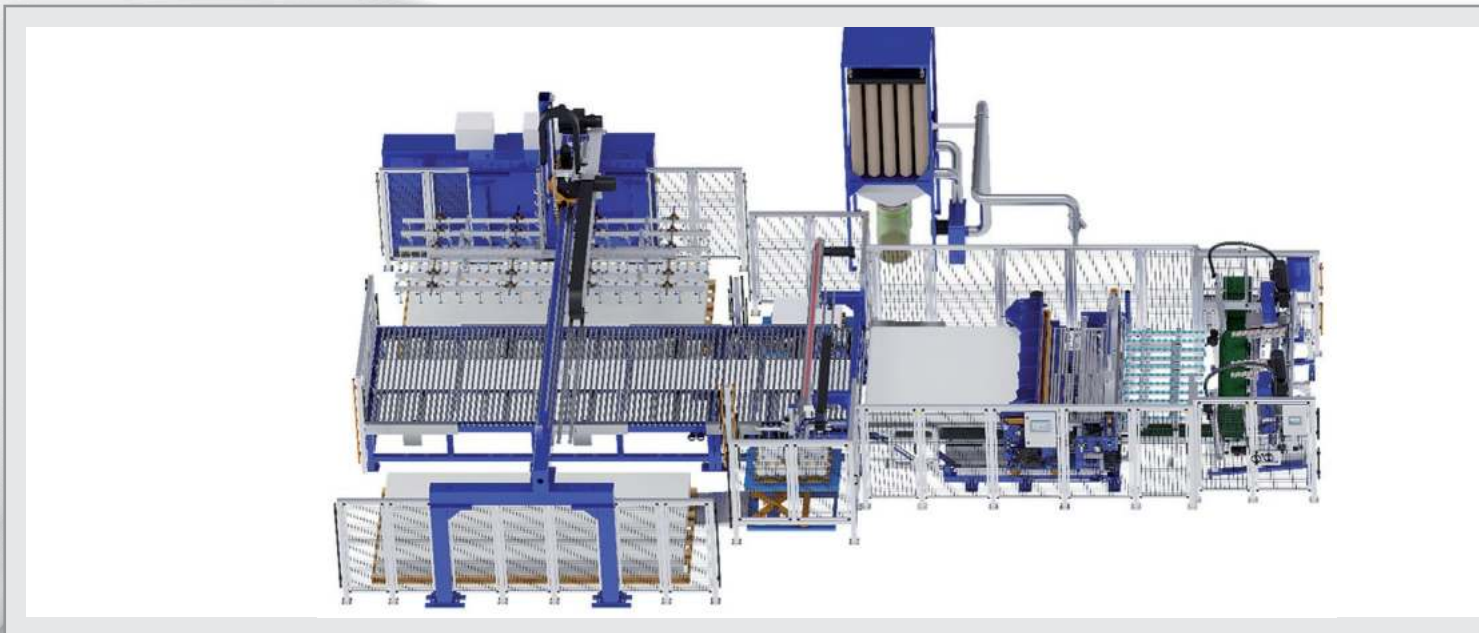

### Cross Cutting Combination

enables optional sawing or cutting in one machine.

Optional available with:

- Hydraulic driven scissor
- Electric driven scissor
- Cross Cut Mill instead of saw
- Cutting angle adjustment



Made in  
Germany



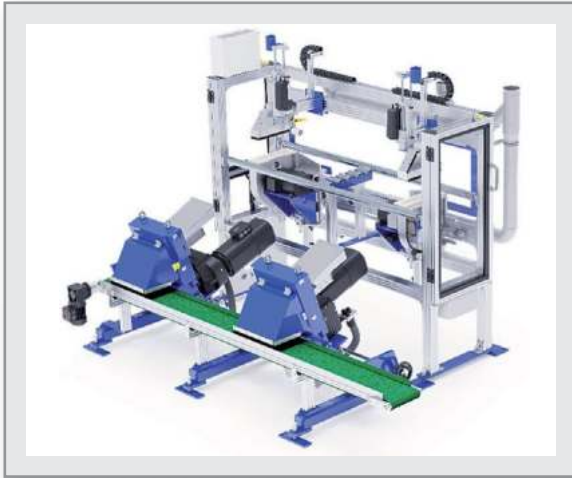

### Edge Trimming Saw & Trim Strip Chopper

an unbeatable team for longitudinal cutting of your panel and direct shredding of the resulting return material.

The machines are also offered individually with many options.

As a specialist in the field of special machine construction, we always find a solution!



### Pull Off Roller

provides precise regulation and compliance of roller speed and roller force.

#### Optional available with:

- Automatic material run control
- Selection of roller coatings
- Multiple Pull Off Roller version

### Calender

for continuous dimensional accuracy and surface quality.

#### Key data:

- Throughput capacity depending on material 400 - 1300 kg/h
- Line speed 0,5 - 70 m/min
- Line pressure per roller: 100-1300 N/cm



### STEIN Maschinenbau GmbH & Co. KG

Wartbachstrasse 9  
66999 Hinterweidenthal/Germany  
Tel. (+49) (0)63 96-9215-0  
Fax (+49) (0)63 96-9215-25  
stein@stein-maschinenbau.de  
www.stein-maschinenbau.de

## CONTENTS

Firms in this issue	6	Medical Tubing Expertise on Display at MD&M West	29
Imprint	7	Latest Welding Innovations at Medical Device & Manufacturing (MD&M) West	30
<b>Industry News</b>	8	Plastic Film Recycling Directory Launched	31
Calendar	8	Executive Leadership Team New Hires and Promotions Announced	32
Kick-Off for the K Year – Düsseldorf in the Starting Blocks for K 2025	8	Confirmation to Lead the Environmental Protection Agency	32
Fakuma 2026 with New Scheduling	9	Concerns about New Tariffs	32
Circular Economy Startups	9	New Recycling is Real Video Showcases „Recycling Across America“	33
GreenPlast 2025 – Shaping a Sustainable Future for Plastics	10	Keynote Speaker Announced	33
Equiplast 2026 to drive the Circularity of Plastics and Rubber	11	<b>CHINAPLAS 2025</b>	
Plastpol Expo – the Place to Conquer New Markets	12	CHINAPLAS Focuses on Green, Smart, and High-Tech Solutions for a Sustainable Future of the Plastics and Rubber Industries	34
„Laying out and evaluating packaging made from mono-material“	13	<b>Extrusion Tooling</b>	
Swop 2024 Concludes with Success	14	Getting the Most from Your Extrusion Tooling	36
Personalia	15	<b>Pipe Extrusion</b>	
Momentary Setback for Italian Plastics and Rubber Machinery Manufacturers	16	Extrusion System for ABS Foam Core Pipes	39
Centrifugal Pellet Dryer Technology Acquired	17	Measurement Technologie – Case Study	
Recognized as World Market Leader Champion Again	17	Cost Savings in the Production of Pipes	42
50 Years in the Service of Plastics Processing	18	<b>Thermoforming – Case Study</b>	
10-Day Extrusion Tooling Program Launched	19	Success with Machined Thermoformed Parts and Fully Assembled Components	43
Results of the 2024 Market Data Report Revealed	20	<b>Extrusion Technology</b>	
New Head Office Asia-Pacific in Bangkok	20	Think big: a modern line for the production of large-diameter polyethylene pipes up to 1600 mm	46
Expansion	21	<b>Recycling, Film Extrusion</b>	
Rebranding and New Monthly Subscription Service Announced	22	Collaboration – Production of Stretch Film that Incorporates Recycled Content	48
Blow Molding Dies	22	<b>Film Extrusion, Digitalisation</b>	
New Cam-Lock Design Introduced	23	One-Stop Solution for Data-Driven Decisions	49
Ideal Sorting Solution for XLPE Pellets	24	<b>Resource Saving</b>	
<b>Industry News USA</b>	26	Sustainability Report Presented	52
Analyses Released: Fed’s Final Move in 2024, Plastics Industry Impact	26	<b>Blow Molding – From the Research</b>	
December Jobs Report	26	GWDS the Revolutionary Economic, Innovative and Safe Solution to Further Improve the Quality of Blow Molded Parts	54
Tracking Plastic and Rubber Products Inventories	26	<b>Film Extrusion</b>	
Interview with PLASTICS CEO	26	Corporation and the Really Big Thing – Contract Conclusion for a New Stretching Line for Ultra-Thick Simultaneously Stretched Film Applications	57
Polystyrene Recycling Alliance Launches to Expand Recycling Access and Drive Higher Recycling Rates	27		
Supply Agreement Signed	27		
Newly Established Company to Offer Collaborative Robot Automation Systems for Packaging Industry	28		
Provisional Patent for New Drivetrain for Reciprocating Blow Molders Filed	29		





CHINAPLAS 2025 will take place in Shenzhen, PR China, on April 15-18, 2025, and will be themed "Transformation • Collaboration • Sustainability". Expanding from its 2023 edition in Shenzhen, CHINAPLAS 2025 will host over 4,000 international exhibitors, with 380,000 sqm of space across all 19 halls



"We studied machine time, manpower costs and scrap costs, and the return on our investment was about 3 to 4 months. The solution provided by Jorge Lage at Zumbach reduced our previous process for acquiring an accurate measurement from about 2 hours down to 5 minutes," Todd Clarke, Production Manager at SWM International



The swissplast group has quickly grown by focusing on high-quality thermoformed parts and a strong emphasis on service, quality, and delivery speed. In addition to thermoforming itself, key success factors include the machining and assembly of parts. The company relies on machining centers from HG GRIMME SysTech, among others, due to their quality, precision, and dynamics



Tecnomatic announced the supply of its latest high-capacity extrusion line for polyethylene (PE) pipes, specifically designed for pipes with diameters up to 1600 mm, to one of Europe's most distinguished pipe manufacturers. This state-of-the-art line brings together Tecnomatic's cutting-edge Zeus EVO series gearless extruders and the innovative Venus 1600 die-head

In 2024 Moretto achieved an important goal: the publication of the Sustainability Report. Covering the calendar year 2023, it is based on ESG criteria and in compliance with the international GRI standards. The report confirms the company's formal and structured commitment to environmental, social and economic sustainability

Japanese FP Corporation (FPCO) has made a groundbreaking advancement in film technology with the development of the world's first ultra-high-rigidity biaxially oriented polypropylene (OPP) sheet. This innovation is the result of a collaboration with many different companies and Brückner Maschinenbau



## Index of Advertisers, companies and fairs referred in this issue

Adsale	34, Outside Back Cover	Moretto	52
AMAPLAST	16	motan	7
AZO	21	Motan Colortronic UK	18
Balzanelli	51	Orion	27
Brückner	15, 57	PlasMec	23
CHINAPLAS 2025	34, Outside Back Cover	PLASTICS	26, 31
Cobots	28	PlasticsEurope	9
CONEXTRU	11, 39	Plastics Training	22
Davis-Standard	29	Plastpol 2025	12
Equiplast 2026	11	Promaplast	10
Erge	15	Reifenhäuser	20
European Bioplastics	20	Rinco Ultrasonics	30
Fakuma 2026	9	Schall, P.E.	9
Gneuss	48	Sikora	17, 24
GreenPlast 2025	10	Smart-Extrusion	Inside Back Cover
GRIMME SysTech, HG	43	SML	41, 49
Groß, Dr.-Ing. Heinz	54	Stein Maschinenbau	Inside Front Cover+3
Guill Tool & Engineering	Outside Cover, 19, 22, 36	swop 2024	14
Innoform Coaching	13	Targi Kielce	12
K 2025	8	Tecnomatic	25, 46
Koch-Technik	21	Velocity Equipment	29
MAAG	17	VM Verlag	6, Inside Back Cover
Messe Düsseldorf	8	Zumbach	13, 42

# MEDIA DATA 2025

MAGAZINE · WEBSITE · NEWSLETTER

# EXTRUSION

EXPERT MEDIA ON PLASTICS EXTRUSION







The Extrusion International Magazine is published bimonthly by VM Verlag GmbH. P.O.Box 501812, D- 50879 Cologne, Germany

**EDITOR**

Bettina Jopp-Witt (Editor-in-chief)  
T. +49 221 546 1539  
redaktion@vm-verlag.com

**ADVERTISING SALES**

Martina Lerner  
T.+49 6226 971515  
lerner-media@t-online.de

Tanja Bolta  
t.bolta@vm-verlag.com  
+49 15205626122

**ADMINISTRATION**

Alla Kravets  
T. +49 2233 949 8793  
a.kravets@vm-verlag.com

**PRINTING**

maincontor GmbH  
Dr.-Gammert-Str. 13a,  
63906 Erlenbach, Germany  
T.: +49 937294810811  
www.maincontor.de,  
info@frankhohmann.com

**SALES REPRESENTATIVES**

China & Asia  
octavia@ringier.com.hk,  
T. +852-9648-2561  
maggieliu@ringiertrade.com,  
T. +86-13602785446

Tokyo PR Inc. (Japan)  
T. +81 (3) 3273-2731  
extrusion@tokyopr.co.jp

**Reprints, Translation etc**

No part of this publication may be reproduced, stored in a retrieval system, or transmitted, in any form or by any means, electronic, mechanical, photographic, recording or otherwise, without prior permission of the publisher.



[www.smart-extrusion.com](http://www.smart-extrusion.com)



## GRAVICOLOR 30

Gravimetric dosing and mixing unit for injection moulding, blow moulding and extrusion processes.



**ZERO LOSS**

[www.motan.com](http://www.motan.com)





#### plast & printpack alger

24 – 26 February 2025  
Algiers / Algeria  
[www.plastalger.com](http://www.plastalger.com)  
[www.printpackalger.com](http://www.printpackalger.com)

#### ICE Europe 2025

11 - 13 March 2025  
Munich / Germany  
[www.ice-x.com](http://www.ice-x.com)

#### PLASTIMAGEN

11 – 14 March 2025  
Mexico City / Mexico  
[www.plastimagen.com.mx/es](http://www.plastimagen.com.mx/es)

#### 29. Nationales SAMPE Somposium: Clean Energy and Mobility – Shaping a Sustainable Future with Composite Materials

2 - 3 April 2025  
Aachen / Germany  
<https://www.ikv-aachen.de/veranstaltungen/detailseite-veranstaltungen/news/news/detail/29-nationales-sampe-symposium/>

#### Plastics Industry Fly-In

08 - 10 April 2025  
Washington, DC / USA  
<https://e.plasticsindustry.org/>

#### CHINAPLAS 2025

15 - 18 April 2025  
Shenzhen / P.R. China  
[www.chinaplasonline.com](http://www.chinaplasonline.com)

#### FlexForum

22 - 24 April 2025  
Orlando, FL / USA  
<https://e.plasticsindustry.org/>

#### Plastasia

9 – 12 May 2025  
Bangalore / India  
[www.plastasia.in](http://www.plastasia.in)

#### T-PLAS 2025

14 – 17 May 2025  
Bangkok / Thailand  
[www.tplas.com](http://www.tplas.com)



## Kick-Off for the K Year – *Düsseldorf in the Starting Blocks for K 2025*

The K 2025 exhibitor database has been online since mid-January. Now completely booked up, this leading trade fair of the plastics and rubber industry will once again stand out with its participation of international market leaders along the value chain and industry know-how and information galore well before the start of the trade fair.

From 8 to 15 October 2025 K in Düsseldorf will again become the central business hub for the global plastics and rubber industry. It sets clear accents with its motto “The Power of Plastics! Green – Smart – Responsible”. This slogan reflects the industry’s current values and targets and emphasises that plastics are an indispensable component of many sectors that contribute significantly to innovation and progress.

Especially in today’s challenging times K once again proves its outstanding relevance as a world-leading trade fair. It is the place where the entire value chain unites to present top performances and where the challenges of this industry are addressed. No other event boasts such international flair, extraordinary innovative power and such a rich variety of product launches as does K in Düsseldorf.

K 2025 stands for the open dialogue and exchange on innovative



solutions and sustainable developments that forge connections across national borders and continents. Exhibitors from 61 countries will take part in K in Düsseldorf and more than 3,000 exhibitors are expected in the 18 exhibition halls. The fairgrounds are fully booked once again. The exhibitor database of K 2025 can be accessed at [www.k-online.com/2410](http://www.k-online.com/2410).

At [www.k-online.com](http://www.k-online.com) K not only provides details on the event in October already at this early stage but also offers numerous opportunities via other channels to obtain in-depth information about the industry’s current developments and to benefit from the global K Community.

[www.k-online.de](http://www.k-online.de)  
➔ [www.k-online.com/2410](http://www.k-online.com/2410)



## Fakuma 2026 with New Scheduling

Beginning with Fakuma's upcoming anniversary event, revised scheduling will apply – the doors will open already on Monday: The 30th Fakuma will be held in Friedrichshafen from Monday the 12th through Friday the 16th of October, 2026, from 9 a.m. to 5 p.m. "This has been agreed upon together with the Fakuma exhibitor advisory board," reports Bettina Schall, managing director of trade fair promoters P. E. Schall. "All involved parties spoke out in favour of conducting an exhibitor survey regarding event scheduling at the last meeting with the exhibitor advisory board. The result was unequivocal: the majority voted in favour of revised

scheduling for the trade fair," explains Bettina Schall. "We look forward to opening the great family celebration of the plastics processing industry already on Monday in just less than two years!"

"We're looking forward to Fakuma 2026," says Bettina Schall with confidence. "Each and every participant will contribute to providing constructive impetus for tackling current challenges and filling the exhibition halls with life during the five-day trade fair."

➔ [www.fakuma-messe.de](http://www.fakuma-messe.de)

## Circular Economy Startups

At K 2025 the grand startup pitch "Towards Zero" will take place on October 13, 2025, in Düsseldorf. Startups with innovations and technologies that contribute to a circular economy for plastics, the defossilization of the plastics industry, or the reduction of so-called Scope 3 emissions can apply until March 1, 2025.

The event, held on Innovation Monday (October 13, 2025), is hosted by Plastics Europe, the association of plastics producers, in cooperation with VDMA and Messe Düsseldorf. "K is the most important industry event for plastics producers, processors, and recyclers," says Dr. Christine Bunte, Managing Director of Plastics Europe Deutschland. "The fair provides startups with a unique stage to present their ideas for reducing emissions and closing plastics loops to an international audience of experts, potential customers, and investors," Bunte adds.

Thorsten Kühmann, Managing Director of the VDMA Plastics and Rubber Machinery, emphasizes: "Innovative technologies are essential to achieving climate

goals and driving the transformation of the plastics industry. We see K 2025 as the perfect platform for innovative mechanical engineering companies and startups to showcase their forward-looking technology projects and connect with partners worldwide."

"The K 2025 fair, under the theme 'The Power of Plastics – Green, Smart, Responsible,' is centrally focused on new circular technologies and innovative circular products," explains Thomas Franken, Director of K. "To ensure the European plastics industry remains competitive in the global market, the use of fossil resources in plastics production must be significantly reduced. That's why the topic of circular economy takes center stage at the fair."

By 2050, early forecasts suggest that 65% of newly produced plastics in Europe could come from recycled and non-fossil resources.

For more:

➔ <https://plasticseurope.org/de/towards-zero/>



## GreenPlast 2025 – Shaping a Sustainable Future for Plastics

At the official streaming press conference on 26th November for GreenPlast 2025, the conference titled „Shaping a Sustainable Future for Plastics“ was introduced. This event will take place on the same dates as the exhibition, which will be held in Milan from 27 to 30 May 2025.

With Europe at the forefront of adopting sustainable practices and a continuously evolving regulatory context, the conference will serve as a platform for international collaboration, enabling stakeholders to exchange ideas and drive meaningful change across borders. The conference coordinators, AMI (Applied Market Information) and Promaplast, have collaborated to curate



**27-30 MAY 2025 • MILANO**  
EXHIBITION AND CONFERENCE  
FOR A MORE SUSTAINABLE  
PLASTICS AND RUBBER INDUSTRY



a comprehensive programme, organised into thematic sessions, covering key aspects such as: plastics waste management, materials recycling, energy efficiency, plastics sustainability, and bioplastics.

The names of the first confirmed speakers, divided by day and the topics they will address.:

**Day 1 - Strategies for Sustainability:** The conference will open with talks from experts and industry leaders from companies such as Lavazza, Gruppo Happy, and the European Plastics Converters association EuPC, who will discuss the legislative aspects of plastics waste.

**Day 2 - Sourcing Plastic Waste:** This day will focus on the procurement of sustainable materials, with an initial overview of the European markets by AMI and talks from experts in the waste management sector, followed by a presentation on automated plastic waste sorting.

**Day 3 - The Future of Mechanical Recycling:** Day three will begin with an exploration of the future of plastics recycling, followed by a session dedicated to closing the loop in plastic recovery processes, featuring experts. The day will conclude with a technological presentation on upcycling, with case studies from Sirmax.

**Day 4 - Chemical Recycling and Polymer Innovation:** The final day will focus on the role of chemical recycling in transforming plastic waste into valuable resources. Presentations will examine the most significant advances in recycling technologies and sustainability projects related to packaging reuse. Leading polymer producers will discuss progress in research and development of sustainable materials.

PROMAPLAST srl  
➔ [www.greenplast.org](http://www.greenplast.org)



## Equiplast 2026 to drive the Circularity of Plastics and Rubber

Meeting for Plastics and Rubber, will return from June 2 to 5, 2026, at the Gran Via venue of Fira de Barcelona. It will bring together the key players in the sector to showcase solutions that reduce the environmental impact of these materials and promote their circularity across various industries.

In 2026, Equiplast aims to expand its offerings and international scope, hosting 400 exhibitors, over 30% of them from outside Spain, to attract more professionals from companies specializing in plastics and rubber transformation and recycling. These companies cater to industries such as packaging, automotive, construction, furniture, and logistics, among many other sectors reliant on these raw materials.

The trade show, trusted by leading firms and organizations in the Iberian market, will showcase at Pavilion 3 of the Gran Via venue a range of products and technologies, including plastic transformation machinery, peripherals, parts and components, molds and dies, raw materials and additives, semi-finished and finished plastic products, as well as environmental and recycling solutions. There will also be equipment for measurement, control, and automation, dedicated hardware and software, industrial and occupational safety services, subcontracting options, and research and technology transfer centers.

The president of the Equiplast 2026 Organizing Committee, Bernd Roegele, commented, "The trade fair will provide an excellent opportunity for companies in plastics and rubber transformation and recycling to incorporate innovations and swiftly adapt their activities to the circular economy model. Furthermore, Equiplast will demonstrate that plastic has countless lives and is part of the solution for achieving a more sustainable environment."

One of the main activities of the next edition of Equiplast will be "Rethinking Plastics," an initiative



gaining greater prominence and extending beyond the trade fair itself. It will highlight experiences in responsible production, management, and recycling of plastics and rubber across different industries. This space will feature a showroom of innovative products, showcasing solutions made from 100% recycled plastic, biodegradable materials, or renewable sources, as well as other rubber-related materials applied in various sectors. For the first time, it will also include a program of conferences and networking opportunities, bringing together experts to discuss and share practical cases on circularity, fostering a more sustainable and collaborative industry.

According to Xavier Pascual, Director of Equiplast 2026, "Our mission as a leading trade fair is to drive innovation and circularity in the plastics and rubber industry, offering a highly practical space where companies and professionals can do business, exchange knowledge, and present cutting-edge solutions that transform the sector."

[www.equiplast.com](http://www.equiplast.com)

## CONEXTRU extruders designed for PE & PP and technical polymers:

**CONEXTRU**



RELIABLE & SHORT IN DELIVERY



HIGH IN PERFORMANCE & EASY TO OPERATE



BUILT WITH HIGH QUALITY EU COMPONENTS



[www.conextru.eu](http://www.conextru.eu) | [dobrowsky.j@conextru.eu](mailto:dobrowsky.j@conextru.eu)



## Plastpol Expo – the Place to Conquer New Markets

*The 29th International Fair of Plastics and Rubber Processing PLASTPOL – 20-23 May 2025 at Targi Kielce.*

In the face of challenges, the plastics industry keeps developing globally and in Poland, with Poland being the processing leader in Central and Eastern Europe. The market value continues to grow, and investments in innovative technologies are increasing. Kielce's May Plastpol is the arena for presenting global solutions; as the event becomes even more international, it plays a significant role in creating new businesses.

The Plastics Europe Polska Foundation report "PLASTICS – FACTS 2024 IN A NUTSHELL" estimates that global production of plastics in 2023 increased to 413.8 million tonnes, of which 374.2 million are plastics from non-renewable raw materials, constituting over 90% of the total. The remaining 36.2 million tonnes were post-consumer plastic recyclates (from mechanical recycling), and a further 3.4 million tonnes were bio-based plastics (3.0 million), chemically recycled plastics (0.3 million) and CCU technologies (0.1 million). What is essential; the investments outlays Europe's the plastics and rubber products production sectpe have been growing at a rate similar to that of the entire industrial processing industry for over 10 years. In 2023, expenditures amounted to PLN 7.36 billion, more than twice the amount in 2013 (PLN 3.28 billion).



"Having observed the Polish, European and global plastics industry trends, we are perfectly aware that companies are striving for development. Enterprises plan to introduce innovative technologies, automate work, use artificial intelligence solutions, and, above all, enter new markets and acquire contractors. In response to these aspirations, we focus on the increasingly firm internationalisation of our Plastics and Rubber Processing Fair," says Kamil Perz, Plastpol Project Director at Targi Kielce.

Let us recall 2024 trade show with 603 exhibitors from 31 countries who presented their offers. Germany, Austria, Latvia, Japan, Belgium, the Czech Republic, China, Denmark, France, India, Portugal, the United States, Switzerland, Taiwan, Great Britain, Turkey, and the United Arab Emirates were represented at the expo.

"According to all indicators, the list of countries and their representatives will definitely be more extensive. Conferences and trade fairs in Asia, Europe, and the Middle East have offered us the opportunity to meet with many representatives of companies from different parts of the world. The results of these discussion are on their way and bear the fruit; companies book exhibition stands at the Plastpol. The exhibition space which has been earmarked for them is impressive. The number of new companies keeps growing and includes representatives of trade fair centres from India, which is a very absorbent market in this sector of the economy," explains Kamil Perz. "Plastpol is not only the largest industry event in Central and Eastern Europe but also one of the most important on the entire continent. Expanding our offer to new markets strengthens the show's global significance and reach."

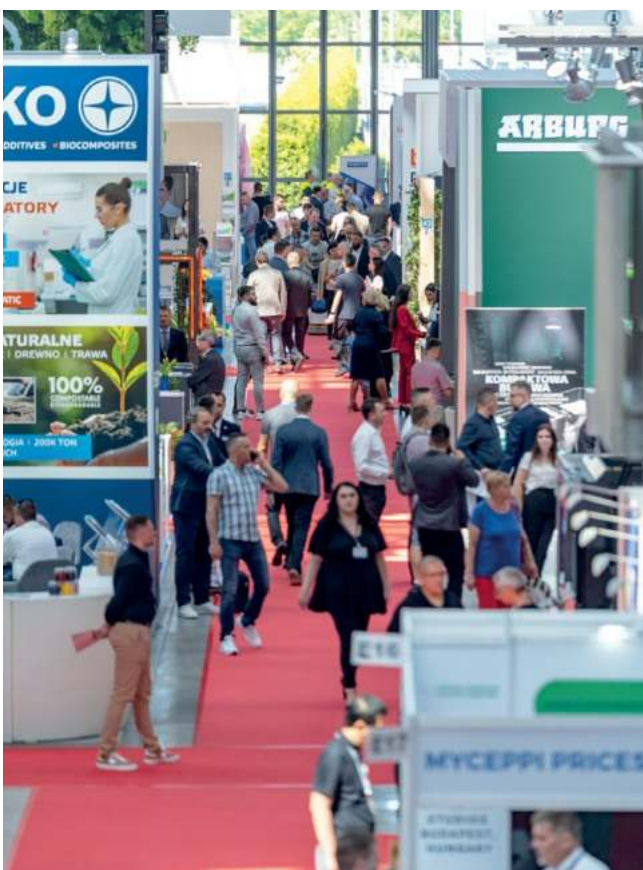



## „Laying out and evaluating packaging made from mono-material“

11 March 2025, Online, English

Mono-materials are the trend in film packaging today. What are the reasons for this trend? The available materials for packaging made of monomaterials that are typically used for food packaging are examined.

The focus is on polyethylene (PE) and polypropylene (PP) as well as copolymers of polyolefins such as EVOH.

It shows which pitfalls need to be considered with monomaterials and which systems are already implemented on the market today, thus providing guidance

to manufacturers of film packaging as well as buyers and brand owners.

Particular attention is paid to processability in the manufacturing process, but also in packaging and application.

► [www.innoform-coaching.de/webseminar/laying-out-and-evaluating-packaging-made-from-mono-material-from-film-structure-to-application-2025](http://www.innoform-coaching.de/webseminar/laying-out-and-evaluating-packaging-made-from-mono-material-from-film-structure-to-application-2025)



SWISS PRIME MEASURING SINCE 1957





**2000+**  
Globally installed systems



**up to 8000**  
Scan rate (scans/s)



**1-8**  
Measurement points



**0.08**  
Wall thickness (mm)



**0.2 ... 400**  
Object diameter (mm)

## UMAC® Ultrasonic Wall Thickness Measurement Solutions for the Extrusion of Plastic Pipes



### Benefits:

- ✓ Utilizes ultra-sonic technology to accurately measure wall thickness and concentricity of up to 5 layers simultaneously
- ✓ Measurement of ultra-thin wall thickness down to 0.08 mm and of products with sizes from 0.2 mm to 400 mm
- ✓ Allows for continuous in-line measurements and real-time data acquisition during the extrusion process, ensuring consistent quality control
- ✓ Offers reduced setup times, raw material savings, scrap reduction and fully automated control
- ✓ Over 2000 installed systems, successfully used all over the world



## swop 2024 Concludes with Success

Shanghai World of Packaging (swop) came to a successful close on November 20, 2024 in Shanghai, China, marking a remarkable conclusion to the annual grand show for the packaging industry in Asia. This year's event stood out as a premier annual exhibition, highlighting a fresh vision and a deep alignment with the dynamic needs of the market. With a focus on globalization, swop has firmly established itself as an essential platform for exhibition, communication, and collaboration across the entire packaging value chain.

Covering more than 65,000 square meters, swop 2024 attracted 903 distinguished companies from across the globe, including those from China, Germany, Spain, Finland, the United States, and many other countries and regions. The event drew 33,192 trade visitors from around the world, offering a vibrant space for exhibitors and buyers to engage in fruitful discussions and explore opportunities for collaboration in response to the evolving landscape of global supply chains.

Evian Gu, General Manager of Messe Düsseldorf (Shanghai) Co., Ltd., said: "As an essential bridge connecting production and consumption, the demand for the packaging industry continues to grow. This surge not only highlights the vitality of global trade but also reflects the ongoing drive across industries to innovate and elevate the quality of product packaging. As a member of the interpack alliance, swop benefits from extensive support that boosts its international reach and influence."



Rita Chu, Vice Chairman of The Adsale Group, said, swop has always been a bellwether for industry hotspots and trends, and this year is no exception, delivering an impressive array of highlights. "Sustainability" can be said to be a consensus within the global packaging industry, while "going overseas" represents a new blue ocean for numerous enterprises to expand into. This year, swop participants from all walks of life can not only gain insights into the latest dynamics and technological trends in the packaging industry but also find ideal solutions tailored to their own development needs.

## Highlights of swop 2024 – Showcasing Cutting-Edge Packaging Industry Technologies and Development Trends

- Spotlight on digitalization, intelligence, and automation in packaging equipment and new technologies
- Focus on packaging containers and tableware production lines, showcasing innovative technologies and eco-friendly materials
- Leading the green revolution in packaging: Showcasing innovative eco-friendly materials
- FMCG Packaging Pavilion at swop 2024: Empowering brands to shine



The International Pavilion, a standout feature of swop 2024, was proudly supported by the "interpack alliance". The event hosted a distinguished roster of internationally renowned exhibitors. These exhibitors presented cutting-edge packaging solutions from around the globe, demonstrating new quality productive forces driving the international packaging sector. With its strong focus on emerging trends, swop continues to solidify its position as a genuine hub of innovation and a premier platform for industry dialogue and collaboration.

A Series of Concurrent Events Creates a Premier Platform for Industry Exchange. In its pursuit of establishing a world-class communication platform and reinforcing its role as an industry trendsetter, swop 2024 hosted a diverse range of expert-led forums and technology exchange sessions. These events brought together industry leaders, scholars, and corporate representatives to deliver comprehensive insights into the latest trends in packaging.

swop 2025 will be held from November 25 to 27, 2025, at SNIEC (Shanghai New International Expo Centre) in Shanghai, China.

## Personalia

The Brückner Group, a market leader in engineering of machinery and equipment for processing plastics and alternative materials. Its continuous global success is based on a forward-thinking, long-term personnel strategy. This approach enables the company to consistently filling open management positions from its own international organisation.

### A Veteran Departs

Helmut Huber, Managing Director of Sales and Project and Product Management at Brückner Maschinenbau GmbH, retired at the end of 2024. Over his 33-year tenure, Huber played a pivotal role in the company's growth, serving in various positions including technical buyer, Head of Assembly, project manager, Head of Project Management, and since 2016, Managing Director and Chief Sales Officer (CSO). His term included the record-breaking year of 2021, with nearly 80 film stretching lines sold.



From left to right: Sebastian Lange (CEO Brückner Servtec since 01.01. 2025), Dr. Axel von Wiedersperg (CEO Brückner Group), Helmut Huber (CSO Brückner Maschinenbau until 31.12. 2024), Markus Gschwandtner (CSO Brückner Maschinenbau since 01.01. 2025)

### An Outstanding Successor

Effective January 1, 2025, Markus Gschwandtner will succeed Helmut Huber. Gschwandtner has over 35 years of experience in the film stretching industry, having excelled as the Regional Sales Manager for China and later as Head of Sales for the Eastern region at Brückner Maschinenbau. Since 2016, he has demonstrated exceptional leadership as Managing Director/CEO of Brückner Servtec, overseeing sales and technology and driving the company's growth.

### Replacement at Brückner Servtec

Sebastian Lange will succeed Markus Gschwandtner as of January 1, 2025. Lange started his career at Brückner Group in 2018 as a Senior Sales Manager at Brückner Maschinenbau. He later moved to Brueckner Group USA as Vice President of the Film Division, where he significantly expanded the division's expertise and strengthened Brückner Servtec's presence in the US market over the past five years.

Dr. Axel von Wiedersperg, Managing Director/CEO of Brückner Group, commented on the successful personnel strategy: "We are delighted to manage the succession of key positions with such foresight. The appointments of Markus Gschwandtner and Sebastian Lange demonstrate that long-term career planning benefits everyone involved. The international experience our leaders have gained ensures Brückner Group's commitment to excellence, benefiting our employees, our Group, and our customers worldwide."

Brückner Group SE  
 ► [www.brueckner.com](http://www.brueckner.com)



ERGE Elektrowärmetechnik - Franz Messer GmbH  
 91220 Schnaittach - Hersbrucker Straße 29-31  
 Tel. +49/9153/921-0 Fax +49/9153/921-117  
[www.erge-elektrowaermetechnik.de](http://www.erge-elektrowaermetechnik.de)  
 mail: [verkauf@erge-elektrowaermetechnik.de](mailto:verkauf@erge-elektrowaermetechnik.de)

HEIZEN

HEATING

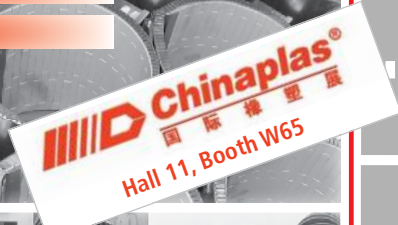

TROCKNEN

DRYING

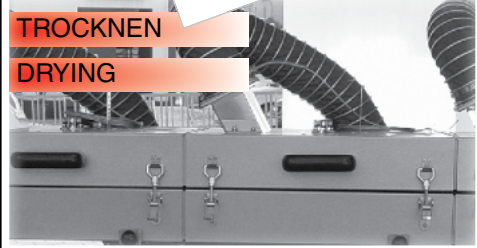

REGELN

CONTROLLING

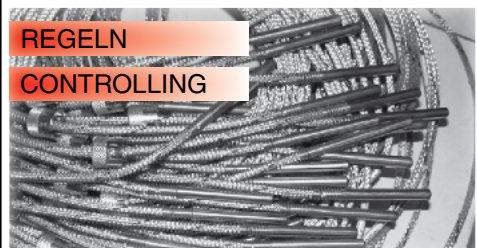

ELEKTROWÄRME TECHNIK FRANZ MESSER GMBH



## Momentary Setback for Italian Plastics and Rubber Machinery Manufacturers

The 2024 full-year forecast developed by the MECS Study Centre of the trade association Amaplast indicates a drop of approximately nine percentage points in Italian production of plastics and rubber processing machinery to an estimated value of 4.35 billion euros. These figures reflect those expected for exports – the historical engine for the industry, which have exhibited a downward trend over the course of the year, although at a lower rate than other industrial sectors and other international competitors – which are expected to come in at 3.25 billion euros.

Imports, on the other hand, appear set to close the year with a bigger drop, on the order of -15%, feeling the effect of truly weak domestic demand. Of course, the post-pandemic recovery, which grew progressively in the three years 2021-2023, partly thanks to tax incentives, was never expected to continue indefinitely. Additionally, the protracted process of determining how to implement the measures provided in the Transition 5.0 plan has led to a pause in investments by Italian customers. Slowdowns in the automotive industry are also no small source of concern for businesses, especially because they are having a heavy impact on various European markets: Germany - Italy's long-term trading partner - first and foremost. International economic and geopolitical uncertainties are felt not only in nearby markets but also in others that are farther afield but still of prime importance to Italian plastics and rubber processing systems manufacturers.

ISTAT analyses of export flows for the period January-September 2024 show that Europe, while again representing the prime sales area for Italian-made products in the sector, has lost five percentage points in total value, a result that mirrors the trend in the EU, burdened by setbacks in important markets such as Spain and Poland (whereas, oddly, Italian sales to German converters have remained steady overall). The drop is even bigger in sales to the CIS, which have been halved mainly due to a collapse in sales to Russia. With the continuing embargo on sales of processing equipment in this market, Chinese competitors are commandeering a greater share of this market. On the other hand, exports have increased to various non-EU destinations, most notably to Turkey and the United Kingdom.

The average trend in exports to the Americas has shown little dynamism: in the north, sales to Mexico continue to go well while those to the United States are slowing down; Brazil still leads in the south but not strongly enough to counterbalance a drop in sales to historical partners such as Argentina, Peru, and Chile. To confirm the interest in the Mexican market, which also represents a bridge to other markets in the area, a new trade promotion unit, the Oficina Italiana de Promoción México, which will provide support to businesses in their trade activities, was recently instituted

in collaboration with the machine tool association Ucima.

The Asian area shows a clearly positive trend, especially the Far East, characterized by the noteworthy acceleration in sales to China (although the value is well below than the average reached by Germany), in spite of the local economic difficulties, as well as to India, Thailand, and Indonesia, just to name the most notable markets.

Sales are also accelerating in the Middle East boosted by strong demand from the Emirates and Israel (although Saudi Arabia has tended to apply the brakes).

As regards Africa, there is a considerable discrepancy between the two main geographical areas: a strong increase in flows to the sub-Saharan region (sales have more than doubled to South Africa and there are peaks in Cameroon, Angola, and Tanzania), contrasting with the poor performance of the Mediterranean countries, with the only positive result coming from Morocco: along with Algeria (which, however, has other problems), it is the only country that did not experience the upheavals of the Arab Spring.

"As regards 2025, it is not easy to make predictions," stated Massimo Margaglione, President of Amaplast. "The ability of Italian manufacturers of technology for plastics and rubber processing to adapt to changing markets and propose technologically advanced and flexible solutions has to be balanced against the growing complexity of global scenarios. As things stand now, we can rule out a modest rebound, with a return to positive growth in the principal indicators for the industry on the order of one or two percentage points. The hope is for a more robust recovery in the domestic market, thanks to the effective introduction of the provisions in Transition 5.0, with the adoption of all the measures provided by European directives for sustainability and energy savings in production processes. However, we can not delineate a more precise outlook until after the first few months of the year have passed."

Sustainability and energy savings will represent the core of the second edition of the exhibition-convention GreenPlast, organized by the Amaplast services company (Promaplast srl) for 27-30 May 2025 at the Fiera Milano fairgrounds in Rho-Pero. Complementing the exhibition section - with companies representing the full breadth of the plastics and rubber industry, from materials to machines, from processes to services - the conferences coordinated by AMI-Applied Market Information will address the key aspects such as the management of plastic waste, mechanical and chemical recycling, energy efficiency of machinery and processes, bioplastics, and much more.

## Centrifugal Pellet Dryer Technology Acquired

MAAG Group announced that it acquired certain assets on December 20, 2024 from Carter Day International, Inc.'s petrochemical division, which specializes in dewatering and drying equipment for the plastics industry.

The acquired drying technology will become part of MAAG's product portfolio, providing additional high-capacity solutions in MAAG's pelletizing systems. This addition of highly engineered products and proprietary technologies will enable MAAG to expand its market presence while providing efficient solutions to a wider range of customers' needs.

With production sites and service centers across Europe, the USA and Asia, MAAG's global footprint will facilitate greater product availability and high-quality service for all customers worldwide.

"This acquisition adds a highly-complementary high capacity dryer technology to our existing product portfolio, further establishing ourselves as the go-to provider for efficient and effective solutions to meet our customers' ever-growing needs," said Ueli Thuerig, President of MAAG Group.



MAAG Group

[www.MAAG.com](http://www.MAAG.com)

Ueli Thuerig, President MAAG Group

## Recognized as World Market Leader Champion Again

In 2025, SIKORA from Bremen is still one of the 520 secret world market leaders in the German-speaking economic area. This is the result of a study conducted by the University of St. Gallen in cooperation with the magazine *WirtschaftsWoche* and the Academy of German Business Leaders.

Since 2016, SIKORA has been represented for the seventh time in the ranking of the world market leaders champions. This is published annually by *WirtschaftsWoche*. Around 520 companies are evaluated and selected by the University of Sankt Gallen and the Academy of German Business Leaders according to defined criteria. The awarded companies occupy first or second place in at least one relevant market segment and achieve an annual turnover of at least 50 million euros, of which at least half is generated abroad on three or more continents. Only official figures are included in the evaluation, such as published annual financial statements in the Federal Gazette or the latest financial statements of listed companies. In the current survey, SIKORA was recognized as one of three Bremen-based companies.

"For more than 50 years, we at SIKORA have been investing in fu-



From left: Dr. Christian Frank (CEO at SIKORA) and Holger Lieder (Executive Board at SIKORA) are pleased about SIKORA's renewed award as world market leader champion 2025

ture-oriented technologies," says Dr. Christian Frank, CEO at SIKORA. "The renewed award as world market leader champion is a confirmation of our innovative strength and the great commitment of our team. Our goal remains to continuously offer our customers solutions of the highest quality through new technologies and product innovations."

Every year, SIKORA invests more than 10 percent of its revenue in the research and development of new measuring and control technology

as well as inspection, analysis and sorting systems for quality assurance during the production of wires and cables, tubes, hoses, pipes and sheets, optical fibers or plastics. With more than 400 employees in Bremen, Germany, and its 13 operating international subsidiaries, the company offers innovative solutions and customized customer service.

SIKORA AG  
[www.sikora.net](http://www.sikora.net)



## 50 Years in the Service of Plastics Processing

The young engineer Erwin Miller started his career in the plastics industry in 1964. As an employee with entrepreneurial vision, he quickly recognised the potential in this emerging market. In 1974, he ventured into self-employment and founded Colortronic LTD.

Initially, the young company worked from a garage, but by 1976 a company building with an area of approx. 110 square metres was built. With 4 employees by now, a turnover of £86,000 was achieved in 1976. The next step was to take over the Ferromatik agency for Great Britain. From 1985, the company focussed on the peripheral business, which was accompanied by the takeover of all shares in Colortronic LTD and the end of the Ferromatik agency.

Due to the steady expansion of the customer base and turnover, the company building became too small, so that in 1987 an area of around two hectares was acquired and the construction of a new building could begin. Two years later, in the summer of 1989, the company moved into the new building with spacious office, workshop and storage areas.

The next generation, Karl Miller, joined the company in 1990. In 1995, the company building was further enlarged to 2600 square metres. In the same year, Karl Miller became a member of the management board. In 2005, Motan Colortronic developed the part finder, an Internet-based programme for customers to search for spare parts. From then on, customers were able to order common spare parts online.

In 2007, Erwin Miller largely retired from day-to-day business.

*Karl Miller in front of the company's numerous awards*

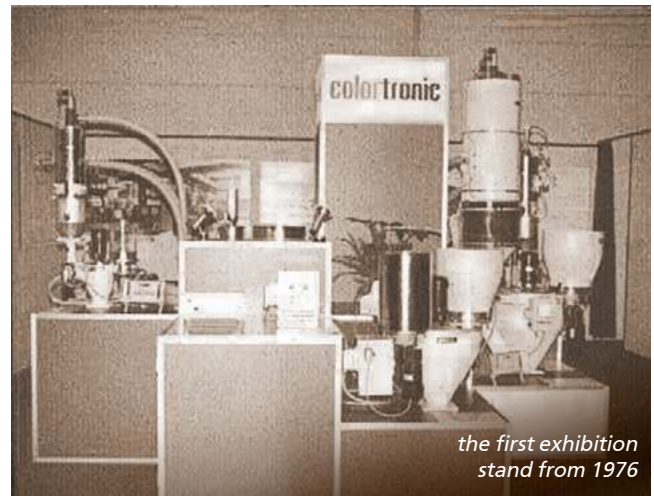

*the first exhibition stand from 1976*



*the current exhibition stand at Interplas in Birmingham 2023*

The introduction of SAP in 2008 meant a huge amount of work in the short term, but this led to a considerable simplification of processes in the medium and long term.

2010 was a decisive year in the company's history: as Colortronic GmbH was taken over by Motan, Motan UK LTD and Colortronic UK LTD merged to form Motan Colortronic LTD. With the enlarged product portfolio, new customer groups were opened up. The customer bases of both companies were merged, creating new synergies. The expertise of the former Motan employees, who were fully integrated into the existing workforce, also offered great potential.

The continuous expansion of the customer base, combined with the strong demand for system solutions and training measures, led to a further remodelling of the company building in 2019. From then on, an enlarged Tech Centre with a large showroom, training rooms and a workshop was available. For example, a conveying line of up to 360 metres has been created for conveying tests.

The energy optimisation of the company building began in 2021. Among other things, all lamps were



*Erwin Miller, founder and chairman of Chesterfield-based Motan Colortronic, has been named winner of the PIA 2017 Unsung Hero Awards for his contribution to the plastics industry over the last 50 years*

converted to LED technology with motion detectors. In 2022, solar modules with an output of 45 kW/peak were installed on the roof and e-charging points were installed. This generates around 50% of the required electrical energy.

Apart from the day-to-day business, Motan Colortronic Ltd was and is heavily involved in the plastics industry as well as in the social environment of Chesterfield. Motan Colortronic Ltd has been honoured several times for its services to the plastics industry. Among other things, Erwin Miller was honoured with the 'Unsung Hero' award at the Plastics Innovation Awards (PIA) in 2017 for his achievements.

In 2024, Karl Miller was named one of the 75 most influential people in the UK plastics industry. As part of Interplas' 75th anniversary celebrations,

75 individuals were honoured who were considered particularly valuable by the industry itself for their contribution to the development of the sector.

A special honour was bestowed on Erwin Miller posthumously in 2022: in recognition of his support, the newly built training ground in Hasland was renamed the Erwin Training Ground in memory of the late Erwin Miller.

After 50 years Motan Colortronic Ltd now has around 30 employees and represents motan, swift by motan and colortronic as well as Regloplas, Herbold, Sesotec and Industrial Frigo.

**Motan Colortronic UK Ltd**  
[www.motan-colortronic.co.uk](http://www.motan-colortronic.co.uk)

## 10-Day Extrusion Tooling Program Launched

Guill Tool has announced its 10-day program. This program applies to eligible tips and dies that will be shipped within 10 business days of receiving the purchase order from the customer.

The company's quality precision tips and dies have been manufactured in the U.S. for 62 years. All Guill extrusion tools are produced using certified and documented quality steel material specifically qualified for the polymer to be extruded. Furthermore, Guill designs tips and dies for any application the customer needs. These feature multi-lumen, stripe, multiple stripe, wire and cable, hose, pipe, tube, fiber optic, blown film, corrugated tube and profile. Dies include face seal, shouldered, snap together, floating, die plates, interchange-



*Close-up of tips and dies*

able die plate and custom dies. Available tips include single and multi-lumen, threaded style, snap together, fixed center shoulder, profile, tapered style and custom.

Guill proudly manufactures its products in the U.S. under the quality standards of ISO 9001:2015 and AS9100:2016.

For more details:



*Tooling cell*

[www.guill.com/tooling-cell](http://www.guill.com/tooling-cell)  
**Guill Tool & Engineering**  
 Tom Baldock, Sales Manager, Extrusion  
[tbaldock@guill.com](mailto:tbaldock@guill.com)



## Results of the 2024 Market Data Report Revealed

European Bioplastics presented its 2024 edition of the market development update during the EBC24 taking place in Berlin, Germany. The report confirms the continuous growth of the global production capacities of bioplastics.

Overall global plastics production continues to rise steadily. This development is driven by rising demand combined with the emergence of ever more sophisticated applications and products. In line, the global bioplastics production capacity is set to increase significantly from around 2.47 million tonnes in 2024 to approximately 5.73 million tonnes in 2029, as the report shows.

“The growth in bioplastics production capacity should be seen against the backdrop of increasing consumer awareness of the environmental impact associated with the overall plastic consumption, underscoring not only the resilience but also the significance of our industry to contribute to sustainable solutions”, states Hasso von Pogrell, Managing Director of European Bioplastics (EUBP).

Bioplastic alternatives exist for almost every conventional plastic material and corresponding application. Due to a strong development of biobased and biodegradable polymers, such as polylactic acid (PLA) and polyhydroxyalkanoates (PHA), biobased polyethylene (PE) as well as a steady growth of biobased polypropylene (PP), the production capacities will continue to

increase significantly within the next 5 years, according to the data.

Bioplastics are used for an increasing variety of applications, ranging from packaging and fibres to consumer goods, automotive, and agricultural products. Packaging remains the largest market segment for bioplastics with 45 percent (1.12 million tonnes) of the total bioplastics market in 2024.

The comparison between the production capacities and actual production in 2024 shows that the bioplastics industry is producing at almost 60% capacity. Although varying in some parts quite significantly from one polymer to another, ranging from 35% to 100%, the average utilisation rate in 2024 is 58% (1.44 million tonnes production vs. 2.47 million tonnes production capacities).

“A potential further approximation of actual production to existing production capacities largely depends on the specific interpretation of recent regulations – keyword PPWR – and other future European legislation relating to the plastics market”, von Pogrell concludes.

The market data update 2024 has been compiled in cooperation with the market experts of the nova-Institute (Hürth, Germany).

European Bioplastics (EUBP)

► [www.european-bioplastics.org](http://www.european-bioplastics.org)

## New Head Office Asia-Pacific in Bangkok

Reifenhäuser has opened its new Head Office Asia-Pacific in Bangkok (Thailand). In future, all sales, service and after-market activities for the Southeast Asian region will be managed centrally from Bangkok. This will give customers direct access to Reifenhäuser's technology portfolio, the best possible on-site service and a faster supply of spare parts via a local warehouse and logistics center.

The Reifenhäuser Group has been active in South-East Asia for a long time – with several regional Sales & Service Units. The newly established Head Office expands and synchronizes the existing capacities.

Marcel Perrevort, CSO of the Reifenhäuser Group, explains: “With the new establishment, we are focusing on the rapid market growth in this region. We are now close to our customers with a powerful organization. There is no

substitute for a close geographical proximity when it comes to building long-term partnerships.”

Reifenhäuser is thus following its global “Close to our customers” strategy in order to better understand and serve market requirements. The investment in local support structures enables faster

responses and better accessibility along the entire customer journey - from the sale of a line to commissioning, service and after-sales support in day-to-day business.

Reifenhäuser Group

► [www.reifenhauser.com](http://www.reifenhauser.com)

*The Reifenhäuser team from the Head Office Asia-Pacific celebrated the opening of the new location in Bangkok on November 29 (Picture credit: Reifenhäuser)*



## Expansion

Just in time for its 75th anniversary, the AZO Group has significantly expanded its international presence. By acquiring its previous sales partner Vedic Pac Systems in India, the company has taken an important strategic step to strengthen its position in the Asian market. This step underscores AZO's commitment to global growth and the promotion of local expertise.

The decision to enter the Indian market was not accidental, as Lukas Zimmermann, Business Development at AZO Holding, reports. India recorded remarkable economic growth in 2023 with a GDP growth rate of 8.2%, significantly exceeding initial forecasts. According to Rajesh Nath, Managing Director of VDMA India, the country is experiencing strong growth across all sectors, particularly in the construction sector, which is being driven by extensive government infrastructure projects. The growing middle class, which is expected to encompass around 300 million people by 2027, also offers enormous market potential.

Daniel Auerhammer, the technological & technical managing director responsible for the AZO Group and now also for Vedic Pac Systems, emphasizes that this integration secures the AZO Group's access to a pool of highly qualified specialists in software development and programming. India is considered a center for IT expertise and innovation. This strategic move allows the AZO Group to expand its development team and benefit from the skills and knowledge of Indian OT specialists. This should accelerate the development of new products and continuously improve existing software solutions.

A decisive factor for the acquisition was also the desire to better meet customer needs. AZO attaches great importance to "glocal"/frugal system applications and the continuous operation of its customers' plants. A competent local sales and service partner is therefore key to a successful market entry in India. With the integration of Vedic Pac Systems, AZO has secured this important market access.

"The integration of Vedic Pac Systems into the AZO Group is an important milestone in our company's global growth strategy. Through close cooperation and exchange between the locations, we want to further strengthen our innovative strength and expand our market position," says Lukas Zimmermann.

The AZO Group is confident that this step will benefit both the company and its customers worldwide.

AZO GmbH & Co. KG

► [www.azo.com](http://www.azo.com)



## EXPAND YOUR CAPABILITIES



**Chinaplas® 2025**  
中国塑料展 2025

Halle 10 - A17

Your competent partner in  
plastics processing mixing,  
dosing, conveying and drying  
Made in Germany

[www.koch-technik.com](http://www.koch-technik.com)





## Rebranding and New Monthly Subscription Service Announced

Paulson Training International, an authorized distributor of Paulson's web-based training programs in Europe, Southeast Asia, Australia, and New Zealand, has rebranded as Plastics Training Online and launched a new monthly subscription system. As part of the rebranding, the company has also introduced a new web site.

"We're thrilled to launch our new brand identity which will give us a competitive edge and enhance our performance as an exclusive reseller of Paulson Training products," said Benjamin Sutch, Managing Director of Plastics Training Online. "We will continue to offer Paulson's complete library of training programs and our high-quality standards, innovation, and uncompromising focus on customer service remain unchanged."

Plastics Training Online's new monthly subscription model provides online access, 24/7, for training that can be directly managed by the user. The web-based, interactive online training solutions are targeted for plastics

processors, material suppliers, machine builders, and virtually any person or company involved in the plastics industry.

"Our training programs are personalized and customized so they fit the individual's needs," said Sutch. Unlike traditional single-seat, one-year offerings which are fixed, the monthly subscription system affords flexibility so that users can mix and match courses. A new pricing scale helps individuals meet their budget needs.

Plastics Training Online offers 20 Paulson courses, covering 100 individual lessons, and provides over 200 hours of overall plastics instruction. Training covers injection molding, extrusion, thermoforming, PET molding, and other specialized training. Courses can be cancelled anytime via an online account.

Plastics Training Online  
[www.plastics.training](http://www.plastics.training)

## Blow Molding Dies

Guill Tool, the global leader in extrusion tooling, offers its Series 1000. This series of blow molding extrusion dies, features a core diameter between 8.5" (219.5 mm) – 10" (254.0 mm). Model 1025 uses material blends which are ideal for medical, automotive and specialty packaging.

Series 1000 is available as single layer, co-extrusion or triple extru-

sion. It adapts to existing extruder layout and in most cases, accepts existing tooling. Features include fixed center or adjustable, built-in cartridge heaters, low inventory, expandable to multi-layer, heated core pin, one-piece body/flow diverter and split feed balanced flow.

Most products should be run fixed. Users need to change only one component to become fully adjustable. The cartridge heaters offer even heat for better flow and ensure there aren't any cold spots. Low inventory produces no burning or stagnation, resulting in quick color change. Since it's expandable to multi-layer, the crossheads run a variety of products. Benefits of the heated core pin and one-piece body/flow diverter are better temperature control and easy

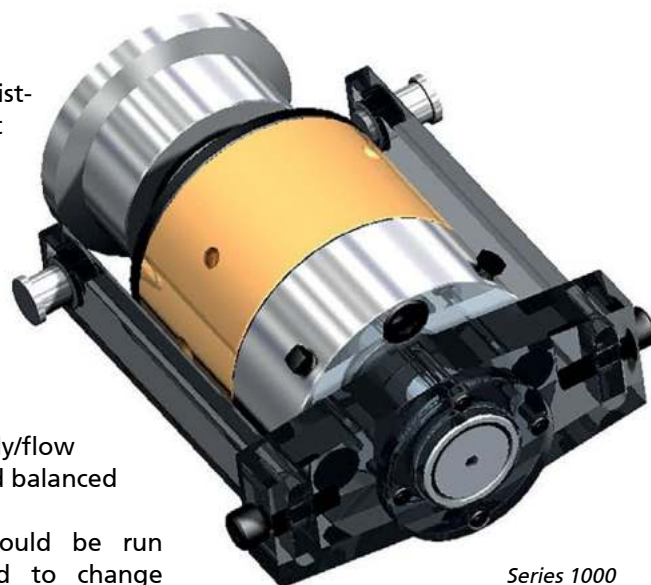

Series 1000



Blow Mold

cleaning/quick change over, respectively. Lastly, the split feed balanced flow achieves concentric walls at all speeds.

For more information:

Guill Tool & Engineering, Co., Inc.  
 Tom Baldock, Sales Manager, Extrusion  
[tbaldock@guill.com](mailto:tbaldock@guill.com)

## New Cam-Lock Design Introduced

Guill Tool, the global leader in extrusion tooling, recently announced the availability of its Cam-Lock design on various crossheads. The Cam-Lock is the same as supplied on the Bullet and will be supplied on additional heads, where applicable. It allows quick and easy assembly and disassembly of the crosshead and eliminates the socket head caps screws. By removing and replacing the internals, a different profile can be extruded in minutes rather than hours. Since the cam lock resets the internals in the right configuration every time, there's far less chance of error, compared to the assembly and misalignment issues with socket set screws. The Cam-Lock offers several features such as: it takes only ½ turn to remove and install the deflector tip and no fastening



hardware is required. Additional features include fast tool changes (threaded retaining ring for the die and threaded tip retainer), dies remove from the front and tips from the back, tooling retainers for gum space adjustment, vacuum connections, simplified cleaning and reduced downtime and operating costs.

For more information:

**Guill Tool & Engineering**  
 Tom Baldock, Sales Manager, Extrusion  
 tbaldock@guill.com  
[www.guill.com](http://www.guill.com)

# “ENSŌ” IN MIXING

*looking for perfection*



*in equipment manufacturing for*

**PVC DRY-BLEND, MASTER BATCH,  
 THERMOPLASTIC RUBBER,  
 POWDER COATINGS,  
 METALLIC BONDING and WPC**



**PLAST IMAGEN**  
 MEXICO 2025  
 MARZO 11-14  
Centro Citimex / Global Air Mexico  
 ITALY PAVILION - stand 532

**EUROPEAN COATINGS SHOW 2025**  
ADHESIVES - SEALANTS - CONSTRUCTION CHEMICALS  
 Hall 4 Stand 4-133  
 25th - 27th March Nuremberg, Germany

**plasmec**  
*Excellence in Mixing*

PLAS MEC S.R.L.  
 Via Europa 79, 21015 Lonate Pozzolo (VA) - Italy  
 phone +39 0331 301648 - comm@plasmec.it  
[www.plasmec.it](http://www.plasmec.it)



## Ideal Sorting Solution for XLPE Pellets

Since plastics are so diverse due to their properties and applications and each market has its own requirements, the sorting requirements are also very individual. The requirements in the XLPE market differ significantly from standard plastics. It is not just a matter of identifying different materials, cross-contamination or coarse impurities.

In addition to the targeted detection and sorting out of the smallest black specks and yellowing, the seamless detection and sorting out of the smallest metal particles is also indispensable. Furthermore, it is essential that the material transport and the type of sorting itself do not introduce any additional external contamination into the material flow.

Another criterion is the space in the production environment. The material flow of XLPE runs by gravity directly from the dust removal on one floor to the sorting on the next floor. Space is limited and a cost factor here. Accordingly, the sorting of optical and metallic impurities should be carried out directly on one floor.

Furthermore, the sorting should be carried out in a way that as little as possible of the good, i.e. clean material, is sorted out. Exactly these requirements were brought to the SIKORA development team by XLPE experts from the industry more than ten years ago. Meanwhile, the fourth generation of

*The PURITY SCANNER ADVANCED reliably detects and sorts the smallest impurities in the raw material*



the PURITY SCANNER ADVANCED is used by numerous customers worldwide.

Experts in the XLPE market are aware of the advantages of the PURITY SCANNER ADVANCED with regard to the precise sorting of the smallest impurities in the range of 25 µm as well as the sorting of metal particles of 50 µm in size in a single material pass. Likewise, the numerous users of the PURITY SCANNER ADVANCED know that only a material transport system with a stainless-steel channel will not bring any impurities with it and that a targeted blowing out with cleaned compressed air using an intelligent approach will cause the least possible ejection of clean material.

This further optimizes production processes, ensures the quality of the XLPE material and, thanks to reduced ejection, contributes to cost-efficient and sustainable production.

*The purity requirements for XLPE pellets are particularly high*





**ALWAYS INNOVATIVE... ALWAYS TECNOMATIC**

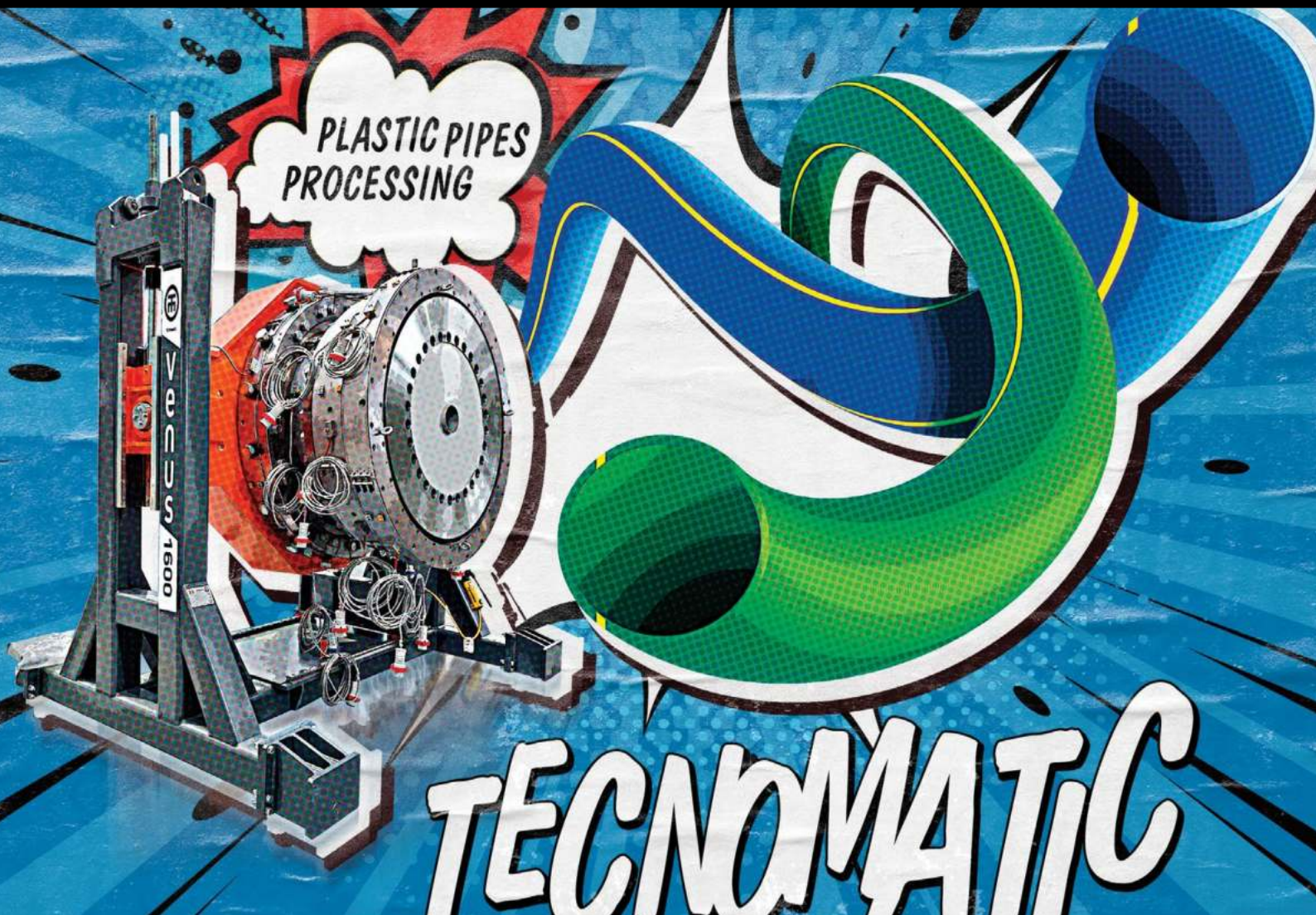

**Boost your extrusion!** To achieve perfection and continuous improvement, Tecnomatic chooses maximum specialization and concentrates its efforts on the

development of extrusion lines for the production of polyolefin pipes with diameter up to 3.000 mm. Technical knowledge, constant research and great passion

allow Tecnomatic to offer high-performance solutions fulfilling all possible customer requirements since 1977.

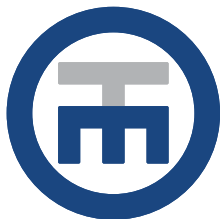

**TECNOMATIC**





## Analyses Released: Fed's Final Move in 2024, Plastics Industry Impact

The Plastics Industry Association (PLASTICS) has released an official analysis on the Federal Reserve's recent decision to cut interest rates and its impact on the plastics industry, authored by PLASTICS Chief Economist, Dr. Perc Pineda.

Dr. Pineda writes, "Despite the macroeconomy continuing to expand in 2024, manufacturing and

housing experienced another year of slumps due to the high-interest rate environment. For the plastics industry, it appears that an interest rate of 4.0% or higher serves as a "threshold rate," restricting capital expenditures and new investment projects both upstream and downstream. Plastics production and capacity utilization continued

to decline, marked by unsustainable spurts in output."

To read the full analysis on the PLASTICS blog page:

► <https://www.plasticsindustry.org/blog/the-feds-final-move-in-2024-whats-next-for-the-plastics-industry/>

## December Jobs Report

PLASTICS has released an official analysis of the December 2024 jobs report and its impact on the plastics industry, authored by PLASTICS Chief Economist, Dr. Perc Pineda.

Dr. Pineda writes, "The U.S. economy's unemployment rate was

4.1% in December, while the manufacturing unemployment rate was 3.5%, consistently remaining below the overall unemployment rate throughout 2024. The manufacturing unemployment rate averaged 3.2% for the full year, fluctuating between 2.7% and 3.6%."

To read the full analysis on the PLASTICS blog page:

► <https://www.plasticsindustry.org/blog/workforce-challenges-2024-december-job-gains-highlight-p pressures-on-us-manufacturing/>

## Tracking Plastic and Rubber Products Inventories

PLASTICS has released an official analysis of plastic and rubber product inventories, authored by PLASTICS Chief Economist, Dr. Perc Pineda.

Dr. Pineda writes, "A closer look at the breakdown of plastic and rubber products inventories highlights how manufacturing has maintained steady production. Work-in-process

inventories averaged \$3.9 billion in 2023 and 2024, with occasional spikes in certain months."

To read the full analysis:

► <https://www.plasticsindustry.org/blog/tracking-plastic-and-rubber-products-inventories/>



Dr. Perc Pineda

## Interview with PLASTICS CEO

While in Albany, New York, for a legislative fly-in Plastics Industry Association's President and CEO, Matt Seaholm sat down with The Capitol Pressroom for an interview on New York's extended producer responsibility legislation and how the plastics industry and lawmakers can work together to truly address waste in the environment.

"There is a shared goal of increased circularity. We want to improve the amount of plastic that is

being recycled. If we start from a place of saying we need to collect, sort and ultimately recycle more plastic, now, we can talk about solutions that do that. Unfortunately, the bill, as proposed, goes so much further and beyond anything that would really be workable in the state. That's why we find ourselves in Albany talking about the issues with this bill versus trying to support something that can get across the finish line."



To listen to the full interview:

► <https://capitolpressroom.org/2025/01/30/plastics-industry-pushes-against-waste-reduction-bill/>

## Polystyrene Recycling Alliance Launches to Expand Recycling Access and Drive Higher Recycling Rates

### *Initiative Aims for “Widely Recyclable Status” for Polystyrene*

The Plastics Industry Association (PLASTICS) announced the formation of the Polystyrene Recycling Alliance (PSRA), marking a significant step toward improving polystyrene recycling across the United States. This collaborative effort unites the polystyrene (PS) and expandable polystyrene (EPS) industries together with a diverse group of stakeholders from brands, converters, and recyclers, united by a shared goal: achieving “widely recyclable status” for polystyrene.

“This collaboration is a huge step forward for polystyrene sustainability, enabling more Americans to recycle a wide variety of polystyrene items,” said Matt Seaholm, President & CEO of PLASTICS. “Polystyrene is inherently recyclable, is being recycled today, and will be recycled at much greater scale in the future. Recycling is real, and we are proud to pursue this initiative at the Plastics Industry Association (PLASTICS) to join the full value chain in working together to promote plastics sustainability.”

In partnership with experts at Resource Recycling Systems (RRS), the PSRA established a comprehensive roadmap to guide this initiative. Initial data indicates that 32% of the U.S. population currently has access to recycle one or more polystyrene items. Several formats are on the brink of qualifying for a “check locally” recycling status. Furthermore, with ongoing and planned industry investments in recycling capacity, PSRA expects recycling access for several polystyrene formats and applications to approach “widely recyclable status” by 2030. We will work collaboratively across the value chain and invest in infrastructure and education to accelerate progress.

From preserving food quality and safety to enhancing pharmaceutical transportation and medical applica-

tions, enabling economical appliance manufacturing and transportation, and contributing to efficient building construction, polystyrene is integral to various industries and used across diverse sectors and applications.

“Polystyrene is an essential material that provides numerous life-enhancing benefits, and a favorable carbon footprint compared to other materials,” said Richard Shaw, Chair of the Polystyrene Recycling Alliance. “Our focus is to expand end-of-life recycling options for all types of polystyrene through strategic investments and partnerships with other stakeholders committed to a circular plastics economy.”

To support these initiatives, the PSRA will establish a recycling investment and education fund aimed at expanding polystyrene recycling throughout North America. These investments will seek to develop and deploy innovative ways to enhance and modernize recycling systems.

“We’re committed to addressing the challenges of recycling polystyrene,” said Patrick Krieger, Senior Vice President, Sustainability of PLASTICS. “By collaborating with communities, material recovery facilities, and drop-off programs, we aim to significantly improve recycling access and education for polystyrene. This is just the beginning, and we are optimistic about our strategy and approach to ensure all polystyrene is recycled at scale.”

To learn more about the Polystyrene Recycling Alliance: [www.PSRecycling.org](http://www.PSRecycling.org).

To learn more about The Roadmap to a Sustainable Future:

<https://www.youtube.com/watch?v=poCRMADE3Fs>

## Supply Agreement Signed

Orion announced it has signed a long-term supply agreement with Contec, which will provide Orion tire pyrolysis oil to produce circular carbon black for tire and rubber goods customers.

The agreement with Warsaw, Poland-based Contec further enables Orion to diversify its sources of tire pyrolysis oil, commonly known as TPO.

“With the ConPyro® TPO supplied by Contec, Orion will be able to make large-scale volumes of circular grades of carbon black that will supply growing demand from the world’s leading tire and rubber goods producers,” Orion CEO Corn-

ing Painter said. “This is yet another way that Orion is accelerating the transition to a circular economy.”

TPO-based manufacturing is the only circular technology that is moving into industrial production to produce high-quality active carbon black. The process takes discarded end-of-life tires and exposes them to high temperatures to produce a feedstock Orion can convert into virgin carbon black.

Orion is the only company that has made circular carbon black from 100% TPO as a feedstock. The company has also demonstrated that its circular products can replace virgin carbon black in many applications.



“At Contec, sustainability is one of our core values. This partnership is a clear confirmation to the market that the industry is continuously evolving, and the circular economy is no longer just a vision for the future - thanks to collaboration with Orion, it is becoming a tangible reality today,” said Krzysztof Wróblewski, CEO of Contec S.A.

Orion S.A.

[orioncarbons.com](http://orioncarbons.com)



## Newly Established Company to Offer Collaborative Robot Automation Systems for Packaging Industry

Cobots has been established as a standalone company which specializes in the development of advanced automation solutions utilizing collaborative robots tailored to meet the diverse needs of small- and medium-sized businesses across the packaging industry. The new company – which targets a range of industries including plastics, pharmaceuticals and beyond – is the sister company of Proco Machinery, a leading manufacturer of automation systems for the blow molding industry,

“Our mission is to redefine the way industries operate by providing cutting-edge cobot solutions. We are dedicated to empowering businesses with innovative automation technologies that streamline processes, improve efficiency, and elevate workplace safety,” said John McCormick, Director of Cobots Inc. “Our team is passionate about delivering tailored automation solutions that drive sustainable growth and success for our clients.”

Collaborative robots (also called co-bots) are designed to work alongside human workers, assisting them with a variety of tasks. Since they are affordable and highly adaptable, manufacturers are eager to adopt this technology and huge growth is expected in the next few years, according to McCormick. The emergence of collaborative robots is tied to the ability to place them alongside humans in small-spaced assembly lines, along with their affordability and ability to be easily trained. They are flexible and can handle short runs and repetitive jobs.

“Collaborative robotic systems are seeing strong growth in the blow molding industry due to the need for greater efficiency and automation,” explained McCormick. “These systems are being designed in such a way that they complement the production line and provide simplified operation, a smaller footprint, and enhanced efficien-



cies.” These collaborative robotic systems reduce the handling of the container and provide an excellent return-on-investment (ROI), says McCormick.

With a ROI of less than a year, cobot solutions are a cost-effective option for the manufacturing industry, providing a safe and low-cost alternative to traditional methods. With the ability to easily adapt to a variety of repetitive manufacturing situations, cobot solutions can be tailored to specific needs. They offer advanced robotic automation benefits without added cost. With a two- to eight-month payback period, it's now affordable for small- and mid-sized manufacturers, according to McCormick.

With lightweight and flexible design, cobots can be easily re-deployed to multiple locations without changing the production layout and support agile manufacturing processes with minimal set-up time. New robotic technology allows programming the cobot movements without a dedicated programmer. Intuitive tools and logical process steps make it easy for operators with no programming experience to streamline their operations.

Cobots also address labor shortages by assisting workers with repetitive tasks, increasing productivity and reducing injury risks. Cobots have safety features that immediately stop motion when contact is made with a person or object, which means they don't require the enhanced safety components associated with industrial robots.

Cobots are impacting a range of manufacturing aspects including material handling, process assembly, quality inspection, and palletizing. They are tailored to meet the dynamic needs of modern packaging industries, ensuring seamless integration and performance.

Sister company Proco Machinery is heavily involved in collaborative robot technology, recently launching a super-compact palletizer system with collaborative robots for blow-molded containers. Proco's latest automation technology also includes the collaborative robotic Robo Packer case packer.

Cobots is currently supplying advanced customized cobot solutions for packaging manufacturers in a range of industries.

## Provisional Patent for New Drivetrain for Reciprocating Blow Molders Filed

Velocity Equipment Solutions, a leading supplier of packaging machinery, has filed a U.S. provisional patent application for an alternative drivetrain technology that will provide major productivity enhancements for reciprocating-screw blow molding machines. The new drivetrain technology is expected to replace traditional technology in current machines dating back to the 1960s, delivering a minimum of 15% energy savings over systems currently employed.

"We believe this is a game-changing innovation that will provide major operational efficiencies for blow molders," said Tom Blaszkow, President of Velocity Equipment Solutions. "Energy represents the Number 2 cost for processors so this new technology will significantly improve the industry's bottom-line results."

Today's more costly and inefficient drivetrain systems consist of some combination of hydraulic cylinders, hydraulic motors, gear reducers, v-belts, and ball spline thrust bearings. In addition, this new simpler drivetrain

will replace these components, yielding dramatically lower maintenance costs over the life of the blow molding machine.

A new reciprocating blow molding machine equipped with the new drivetrain would cost less than a machine with today's existing drivetrain technology, according to Blaszkow. Similarly, an existing machine retrofitted with the new drivetrain would be equivalent in cost to a standard replacement.

Velocity has completed the design of its first machine equipped with the new drivetrain. It is slated for completion by early second quarter of 2025 and has already drawn interest from potential buyers. The new drivetrain will also be available as a retrofit kit for existing machines.

Velocity also announced plans to file a non-provisional patent in February.

Velocity Equipment Solutions LLC

► [www.velocityes.com](http://www.velocityes.com)

## Medical Tubing Expertise on Display at MD&M West

Davis-Standard showcased in-house medical tubing capabilities with Maillefer (a Davis-Standard Company) and its longtime technical partnership with Conair and Zumbach during MD&M West in Anaheim, Calif.. Machinery at the booth included a static silicone tubing line and a running four-lumen PEBAX line, and a running three-lumen TPE bump tubing line and static Davis-Standard 2.5" 24:1 extruder. This machinery range promotes innovation that addresses market demand for tubing used in minimally invasive procedures, home healthcare applications, and wearable medical devices.

The four-lumen PEBAX® tubing line merges the robust in-house medical tubing technologies of Davis-Standard and Maillefer. The lightweight and elastomeric properties of PEBAX® have made it a prevalent material choice for medical applications involving fluid transfer, catheters, and balloon tubing. This running line included Davis-Standard's widely used HPE extruder along with a Maillefer die, vacuum tank, puller/cutter, and conveyor. A Zumbach gauge system and servo air controllers, along with a Conair chiller and drying system, completed the line. Advantages include a conical helically grooved die with flow divider for uniform distribution; precision vacuum tank control (below 0.5 mbar); closed-loop water system with an option to maintain temperatures up to 104 degrees Fahrenheit (40 degrees Celsius); and a compact puller/cutter with an intuitive HMI. DS-eVUE process control will provide intuitive feedback and control for showgoers to monitor line performance.

Davis-Standard exhibited with technology partners Conair Group and Zumbach to run precision multi-lumen taper tubing used in cardiology applications. A Davis-

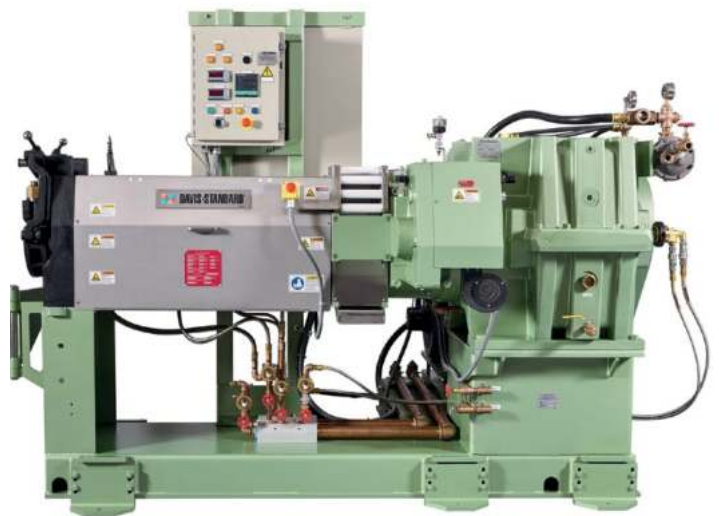

Standard HPE extruder with XEL drive and control system was paired with Conair downstream equipment and Zumbach gauge controls to model this intricate process for producing three-lumen tubing for heart catheters used in minimally invasive therapies such as pressure measurement, imaging, angioplasty, and stent placement. This process requires meticulous dimensional control of a changing taper tubing profile as well as the profiles for each internal lumen. Customers had an opportunity to see how the multi-faceted technical features of each line component, from the extruder to the gauging system to the drying and loading system, make this possible.

Davis-Standard

► [www.davis-standard.com](http://www.davis-standard.com)



## Latest Welding Innovations at Medical Device & Manufacturing (MD&M) West

Rinco Ultrasonics showcased its latest plastics welding innovations for the medical market at Medical Device & Manufacturing West. The company highlighted its next-generation Standard Series ultrasonic welding machines and its new Electrical Motion servo-driven machine, available in 20 kHz and 35 kHz frequencies, which provides superior performance, cost effectiveness, and the latest in user-friendly features for the medical device market.

Both these new welding systems meet ISO 13485 certification standards for medical device manufacturing, and feature a non-volatile audit trail which provides complete traceability of weld parameters, adjustments and any errors or faults that occur.

The next-generation Electrical Motion 20 and 35 machines take ultrasonic welding to a new level, pushing the limits of what customers can achieve in weld quality and repeatability, said Bill Aurand,

Rinco sales manager. "We've developed a more intuitive ultrasonic system that is faster and more efficient to help manufacturers meet today's challenging productivity demands," he said.

An important feature of the next-generation Electrical Motion welding system is a completely redesigned microprocessor operating system which significantly increases screen response time. The Linux Ubuntu operating system is logically structured, self-explanato-

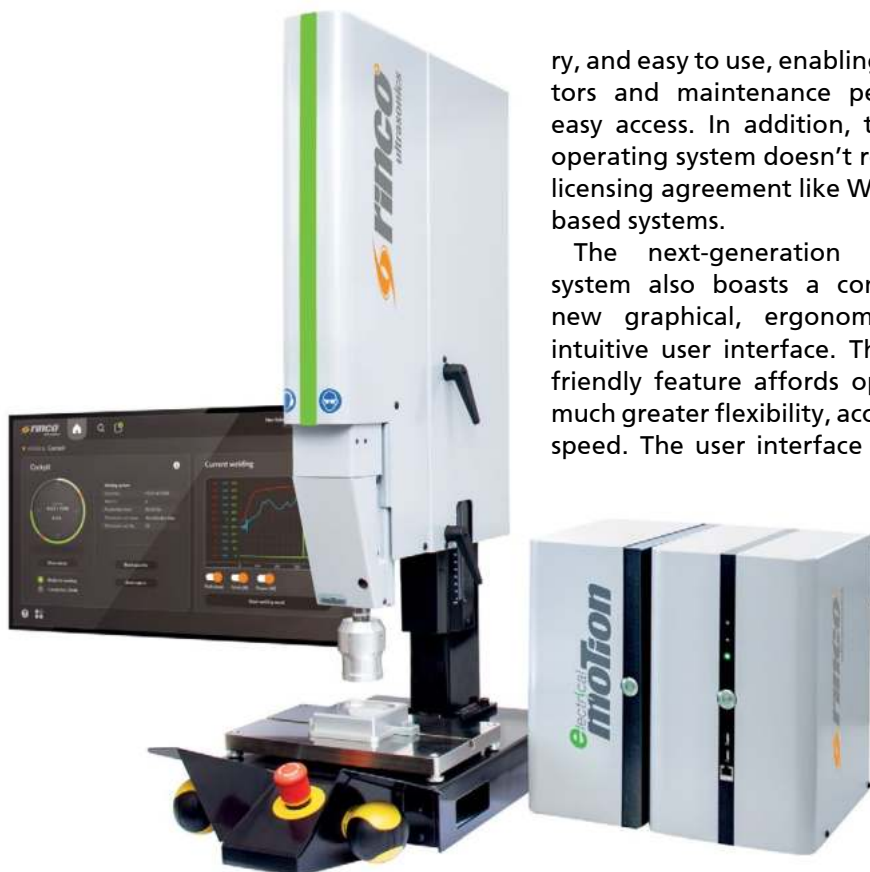

ry, and easy to use, enabling operators and maintenance personnel easy access. In addition, the new operating system doesn't require a licensing agreement like Windows-based systems.

The next-generation welding system also boasts a completely new graphical, ergonomic, and intuitive user interface. This user-friendly feature affords operators much greater flexibility, access, and speed. The user interface is easily

operated via a larger color touchscreen monitor which provides quick and easy operation. The user interface also provides programmable password protection, offering many levels of digital security and protection.

A new stack mounting feature facilitates easy alignment for quick-change tools. The Electrical Motion welder is also fully calibratable and offers permanent audit trails so users can track all system errors and adjustments. To ensure quality and process traceability, all events and changes to the parameters are automatically stored in an audit trail protocol. This permanent audit trail along with Electrical Motion's ISO13485 and Class 6 cleanroom certifications help medical device manufacturers comply with the unique requirements of their industry.

Traceability also helps provide quick diagnosis of any problems. A Rinco technician, with the help of remote maintenance using an internet connection, can quickly identify any issues and, in many cases, directly correct any parameter errors immediately, reducing valuable downtime.

At MD&M West, Rinco also highlighted its next-generation Standard Series workhorse line of ultrasonic welders, available in 20kHz, 35kHz, and 70kHz frequencies. They have been significantly upgraded with enhanced pneumatics, the latest in user-friendly features, and a fresh new look.

The next-generation Standard Series also boasts a completely new graphical, ergonomic, and intuitive user interface. This user-friendly feature affords operators much greater flexibility, access, and speed. The user interface is easily operated via a built-in 10-in color touchscreen monitor which provides quick and

easy operation. The new touch panel generator face has a user-friendly interface which includes advanced weld data graphing.

The user interface also provides programmable password protection, offering many levels of digital security and protection. Improved weld data transfer and storage is significantly enhanced with automatic transfer of welding results to internal and external data carriers and network drives.

The new Standard Series also offers permanent audit trails so users can track all system errors and adjustments. To ensure quality and process traceability, all events and changes to the parameters are automatically stored in an audit trail protocol. Non-volatile storage of all weld alerts and process changes makes setup tampering impossible. This permanent audit trail along with the Standard Series' ISO 13485 and Class 6 cleanroom certifications help medical device manufacturers

comply with unique regulatory requirements.

The new Standard Series also comes equipped with a patented machine status indicator on the front of the machine. A light strip indicates machine status (ready=green, error=red) thus alerting the operator to good and bad parts.

The Standard Series machines boast a robust design and ultra-rigid construction, offering versatility, superior performance, and optimum functionality. The Standard 3000 and 745 are also available with stainless steel housings for use in cleanrooms. Moreover, the Standard 3000 CR is certified to ISO class 6. The Standard 50 is targeted for micro components such as those used in demanding microelectronics applications.

Rinco Ultrasonics

► [www.rinco-usa.com](http://www.rinco-usa.com)

## Plastic Film Recycling Directory Launched

The Flexible Film Recycling Alliance (FFRA) has announced the launch of its new Plastic Film Recycling Directory. This new resource aims to increase plastic film recycling rates across the United States by improving consumer access to recycling collection points, and providing clear educational resources on how to responsibly recycle plastic film.

The directory is part of FFRA's commitment to fostering greater transparency, collaboration, and progress in plastic film recycling. FFRA has pledged the following:

- **Responsible Collaboration:** FFRA is developing a verification program in partnership with third parties, and will work closely with collection and recycling partners to maintain integrity in recycling efforts.

- **Stakeholder Engagement:** FFRA will address all constructive inquiries, share its responses publicly, and encourage stakeholders to sub-

mit requests to evaluate the alliance's impact.

- **Candid Transparency:** Within two years of the directory's launch, FFRA will publicly share verified data on its impact and progress towards increasing recycling rates.

"We are excited to launch the Flexible Film Recycling Alliance's Plastic Film Recycling Directory," said PLASTICS Vice President of Sustainability, Patrick Krieger. "FFRA's priorities include ensuring consumers know where to recycle plastic film and feel confident that their materials are being properly recycled. We believe this directory will play a critical role in increasing plastic film recycling rates across America."

Retailers and recycling depots collecting plastic film are encouraged to join the directory. For inclusion, contact Kurt Kurzawa at [kkurzawa@plasticsindustry.org](mailto:kkurzawa@plasticsindustry.org).

The Flexible Film Recycling Alliance, an initiative of PLASTICS, is dedicated to improving flexible



Patrick Krieger

film recycling by advancing access, education, and recycling rates nationwide. Through its efforts, FFRA seeks to advance a more circular economy for plastic film products.

For more information:

► <https://plasticfilmrecycling.org/>



## Executive Leadership Team New Hires and Promotions Announced



*Matt Seaholm*

The Plastics Industry Association (PLASTICS) has announced a series of new hires and promotions within its Executive Leadership Team, effective January 1, 2025. These appointments reinforce the association's commitment to protect, promote, and grow the industry towards a goal of creating a sustainable plastics industry.

"I'm proud of the team we've assembled at PLASTICS, happy to welcome our new additions and an-

nounce these well-deserved promotions to the Executive Leadership Team," said PLASTICS President and CEO, Matt Seaholm. "As we start the new year, I'm confident this team will continue to represent the entire supply chain of our industry with dedication and deliver the highest value for our members."

### PLASTICS New Hires

Chris Rager will join the PLASTICS team as Vice President of Government Affairs. Chris joins PLASTICS after serving as the head of State Government Affairs for the American Petroleum Institute, where he managed the day-to-day operations of eight regionally based offices and nearly 50 staff members and consultants that covered API's nationwide integrated advocacy capability. With over 20 years of experience in government relations, Chris brings a wealth of expertise from his previous roles and will focus on building a robust government affairs strategy at PLASTICS. His leadership will be instrumental

in advancing PLASTICS' advocacy and policy efforts at all levels of government.

Angela Mealy joins PLASTICS as Executive Director of NPE: The Plastics Show. In this newly created role, Angela will oversee the strategy, operations, budget, project management, and overall success of NPE2027. Angela brings extensive experience from her tenure as Senior Director of Event Services at the Association of Equipment Manufacturers, where she directed three major trade shows.

PLASTICS is also proud to announce the following promotions within its Executive Leadership Team:

Ashley Hood-Morley to Senior Vice President, Industry Engagement.

Patrick Krieger to Senior Vice President, Sustainability and Policy.

Stephanie Strategos Polis to Vice President, Public Affairs.

Apryl Alexander-Savino to Vice President, Events and Marketing.

Mónica Mancilla Cooke to Vice President, Human Resources.

## Confirmation to Lead the Environmental Protection Agency

PLASTICS released the following statement congratulating Lee Zeldin on his confirmation to lead the Environmental Protection Agency and expressing eagerness to work with Lee Zeldin:

"PLASTICS extends our sincere congratulations to Lee Zeldin on his confirmation to serve as Admin-

istrator of the EPA," said PLASTICS President and CEO Matt Seaholm. "As a representative in Congress, Mr. Zeldin balanced thoughtful and responsible environmental policy while supporting businesses and economic growth. We look forward to working with Mr. Zeldin to protect, promote and grow the plastics

industry as we continue to invest in sustainability and circularity."

Earlier this week, the Plastics Industry Association (PLASTICS) sent a letter to Senate Majority Leader John Thune and Senate Minority Leader Chuck Schumer expressing full support for the nomination of Lee Zeldin.

## Concerns about New Tariffs

PLASTICS President and CEO Matt Seaholm issued the following statement regarding the Trump Administration's new tariffs on Canada, Mexico, and China:

"The plastics industry recognizes the importance of securing our borders and combating illegal drug trafficking to protect American commu-

nities. A strong and secure nation is fundamental to economic growth and industrial stability. PLASTICS is concerned about the new tariffs and their impact on U.S. plastics manufacturing and jobs. While we understand President Trump's rationale, a blanket tariff policy could have significant economic conse-

quences, disrupting the movement of essential machines, products, and materials that keep American manufacturers running. A competitive industry requires policies that protect high-quality jobs and ensure stable supply chains across sectors like healthcare, consumer products, and automotive. A strategic, mea-

sured approach to trade is critical to strengthening – not inadvertently harming – U.S. industry.”

“The plastics industry is a cornerstone of American manufacturing and daily life. We look forward to working with policymakers on balanced trade policies that enhance U.S. competitiveness, reinforce sup-

ply chains, and drive continued innovation,” Seaholm concluded.

In 2023, U.S. plastics exports totaled \$74.2 billion, exceeding imports of \$73.3 billion and resulting in a \$958 million trade surplus. This strength underscores the industry’s global leadership; however, new tariffs on key trading partners threaten

supply chains, increase costs, and risk eroding this advantage. To sustain growth and innovation, trade policies must bolster – not hinder – U.S. plastics manufacturing and economic leadership.

➔ <https://www.plasticsindustry.org/>

## New Recycling is Real Video Showcases “Recycling Across America”

The Plastics Industry Association (PLASTICS) has unveiled a new video as part of the Recycling is Real advocacy campaign titled, “Recycling Across America.” This latest installment showcases recycling efforts happening nationwide, featuring companies that have participated in the campaign in 13 states.

Since its launch in September 2023, the Recycling is Real campaign has produced 15 videos, with nine released in 2024. The series spotlights both mechanical and advanced recycling facilities across the United States, highlighting the vital role of employ-

ees in the recycling industry. Featured locations include Atlanta, GA; Madison, WI; North Vernon, IN; Baton Rouge, LA; Portland, PA; Eagle Rock, VA; Rialto, CA; Wytheville, VA; Piqua, OH; Reidsville, NC; Tampa, FL; Kingsport, TN; and Farmingdale, NY.

“Recycling is real, and the ‘Recycling Across America’ video shows that recycling is happening every day throughout the country,” said PLASTICS President and CEO Matt Seaholm. “For over a year now, the Recycling is Real campaign has been shining a spotlight on the people and companies making re-



new year, showing both the public and policymakers that recycling is not only real but feasible, economical, and essential for a circular economy.”

To view the “Recycling Across America” Video:

➔ <https://recyclingisreal.com/>

## Keynote Speaker Announced

PLASTICS has announced Kellyanne Conway as the keynote speaker for PLASTICS’ 2025 Legislative Fly-In and Spring Meeting. Conway will provide meeting attendees with an insider’s perspective on the political landscape in Washington, examining voting trends and providing insight into the priorities and strategies of the new White House and Congress.

“We’re thrilled to have Kellyanne Conway deliver the keynote address at this year’s Legislative Fly-In and Spring Meeting,” said PLASTICS President and CEO Matt Seaholm. “Her deep understanding of the political landscape and firsthand experience at the highest levels of

government will provide invaluable insights for our members as we continue advocating for policies that support manufacturing, innovation, and sustainability. This is a pivotal time for our industry, and we look forward to an engaging discussion on the priorities and strategies shaping Washington.”

PLASTICS’ **Legislative Fly-In and Spring Meeting** will take place from **April 7-9, 2025**. This event connects industry leaders with legislators and their staff, providing a unique platform to educate them about the positive impact of the plastics industry.

Kellyanne Conway served as Campaign Manager of Trump-Pence

2016, making her the first woman in U.S. history to successfully helm a presidential campaign. For nearly four years, Kellyanne served as Assistant to the President and Senior Counselor to the President at the White House, working on a range of issues affecting domestic and global policy.

Conway was Founder and President of The Polling Company, Inc./ WomanTrend a privately-held, female-owned corporation she operated from 1995-2017.

For more information:

➔ <https://www.plasticsindustry.org/flyin/>



# CHINAPLAS Focuses on Green, Smart, and High-Tech Solutions for a Sustainable Future of the Plastics and Rubber Industries



China remains crucial in global economic growth, with a steadily expanding Purchasing Managers' Index (PMI) and confidence in meeting growth targets, solidifying its position as a powerhouse in the global economy. In November 2024, the PMI of China's manufacturing industry reached 50.3%, an increase for three consecutive months, indicating an accelerating pace in the expansion of the manufacturing industry, according to the National Bureau of Statistics of China. Building upon this momentum, CHINAPLAS 2025, themed "Transformation • Col-

laboration • Sustainability," will take place in Shenzhen, PR China, on April 15-18, 2025. Expanding from its 2023 edition in Shenzhen, CHINAPLAS 2025 will host over 4,000 international exhibitors, with 380,000 sqm of space across all 19 halls, showcasing the latest innovations in plastics and rubber solutions. Together with 9 country/region pavilions, CHINAPLAS 2025 will facilitate collaboration along the upstream and downstream industry chains, leading the way with green, smart and high-tech solutions to drive high-quality industrial growth.

## Green: Innovating for Circular Economy

Sustainability and environmental awareness have become global industry trends. In the dynamic landscape of the plastics and rubber industries to be showcased at CHINAPLAS 2025, the concept of a circular economy will continue to be one of the key focuses of the exhibition, highlighting the industry's commitment to sustainability and resource efficiency. By emphasizing the reuse of resources to minimize waste and stimulate economic growth, the exhibition will demonstrate a clear dedication to address-



ing environmental challenges. This focus aligns seamlessly with China's progressive policies promoting sustainability and recycling initiatives, reflecting the industry's proactive stance towards a more sustainable future. Suppliers in the plastics and rubber industries are consistently unveiling biodegradable materials, recycling, and sustainable solutions as they actively propel efforts toward a circular economy.

CHINAPLAS 2025 will feature three thematic zones, namely Recycled Plastics, Bioplastics, and Recycling Technology, covering around 16,000 sqm and gathering leading material suppliers and recycling machine manufacturers, which will present their sustainable technologies and solutions, supporting the industry's goals for environmentally friendly development. Live demonstrations of two recycling production lines, focusing on 'Bottle-to-Bottle Closed-Loop Recycling' and 'Turning PE Waste into Treasure,' will unveil advanced equipment

technology and high-value utilization solutions within the plastic recycling sector. The sports and leisure industry, a promising market for plastics and rubber applications, will also be highlighted at CHINAPLAS with the "SportsTech Chic + Green" event, collaborating with renowned sports brands to showcase the innovation and sustainability of plastics and rubber in sports products. CHINAPLAS x CPRJ will host the 6th Edition Plastics Recycling & Circular Economy Conference & Showcase in Shenzhen, gathering global stakeholders to delve into the latest recycling trends. Collaborating with the China Packaging Federation, CHINAPLAS will first introduce the Sustainable Plastics Packaging Networking Forum, connecting industry experts and exploring sustainable packaging solutions worldwide.

**Smart: Evolving digitally in Manufacturing**

Smart Manufacturing, encompassing technologies like automa-

tion, artificial intelligence and IoT integration, enhances manufacturing processes and revolutionizes industries by boosting efficiency, productivity, and flexibility. By integrating real-time data analytics and interconnected systems, it optimizes operations and reduces downtime, leading to informed decision-making and agile responses to market demands. Implementing smart manufacturing in the plastics and rubber industries streamlines supply chain management and accelerates product launches. Through tools like predictive maintenance, real-time monitoring, and automated quality control, production output and quality is improved that eventually fosters sustainability efforts in the plastics and rubber industries.

The online pre-registration for CHINAPLAS 2025 is open till April 9, 2025.

[www.ChinaplasOnline.com](http://www.ChinaplasOnline.com)

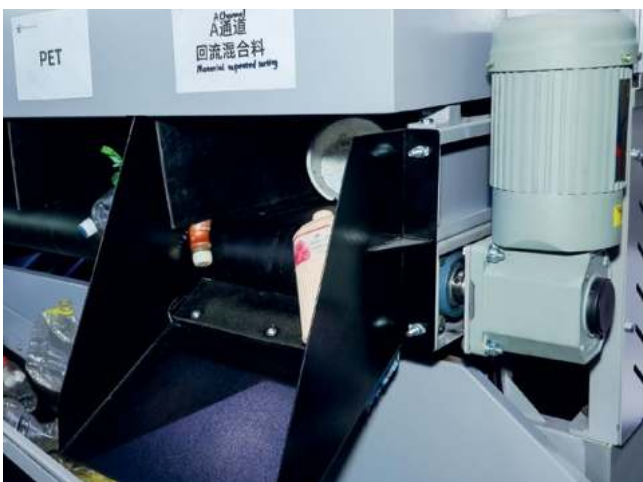



# Getting the Most from Your Extrusion Tooling

*Tooling maintenance improves extrusion efficiency, enhances quality and boosts overall productivity for your medical tubing applications.*

*By: Glen Guillemette, President  
Guill Tool & Engineering*

*Guill 712 Series*

By utilizing state-of-the-art production equipment and processes, machining tolerances are held extremely close on today's multi-lumen and multi-layer medical tubing. It is important to note that any misalignment of the tools may be exaggerated in the final product output. Clean parts, especially with sealing and locating surfaces, are key to product performance and successful end products. These surfaces receive the most care and attention during manufacturing and are the control surfaces that ensure uniformity throughout the tubing. Remember, precision-machined alignments are affected by even a speck of dirt measuring only a few thousandths of an inch. A human hair is about 0.003" (0.08 mm), and since there are many such surfaces in a quality tool, cleanliness is critical.

Checking of the tools for any deformities is also important. Burrs, scratches and scrapes are usually a result of careless handling and/or storage of equipment. Double and triple-layer extrusion heads pose an even greater challenge for mainte-

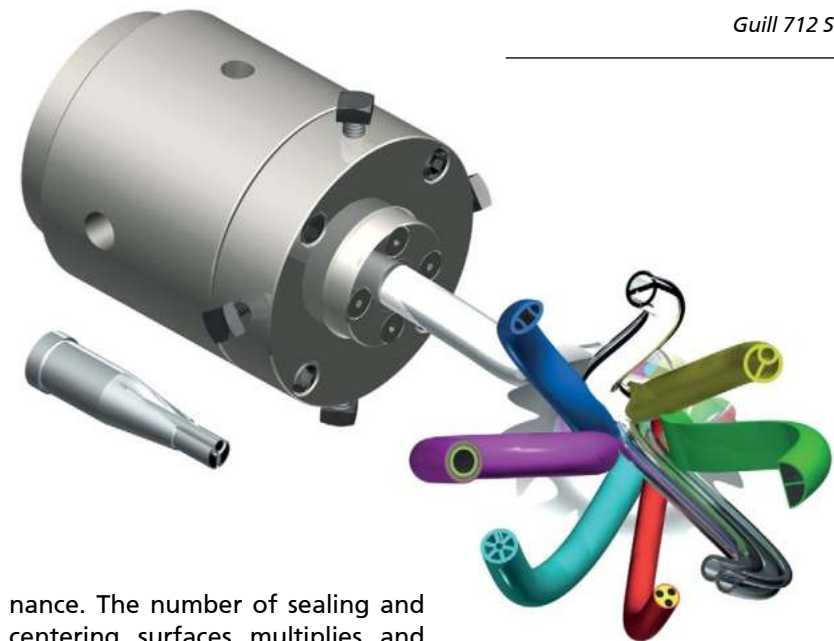

nance. The number of sealing and centering surfaces multiplies and can magnify the results of dirty tools. During changeovers, the head may be disassembled in order to change compounds and/or tips and dies. Foreign matter is usually introduced at this point and residual materials must be thoroughly removed. Physical tool damage often occurs during this phase, due to mishandling and poor storage techniques. These are highly precise parts, but can also be heavy and bulky to remove by hand. Use of a dedicated work cart exclusively reserved and equipped for extruder head maintenance is recommended. This cart along with a supply of spare components and

hardware is easily justified, especially when examining the potential cost savings that result from well-maintained tools. The following should be considered: 1.) Maintain a clean, organized work area with soft and clean renewable work surfaces;

2.) Use a vise with soft jaws, such as copper; 3.) Use special equipment, such as tip removal tools, etc.; 4.) Standard tools include wrenches, soft-faced hammers, etc.; 5.) Maintain a supply of soft, clean rags; 6.) Use cleaning solutions in spray bottle; 7.) Use spare parts as suggested by your tooling supplier, properly organized and stored; 8.) Keep handy your equipment's repair/maintenance manual; 9.) Have a small surface plate to provide a true flat surface;

10.) Use a set of appropriate gauge and tip pins for initial tool location adjustment; 11.) Make sure you have all the proper lifting

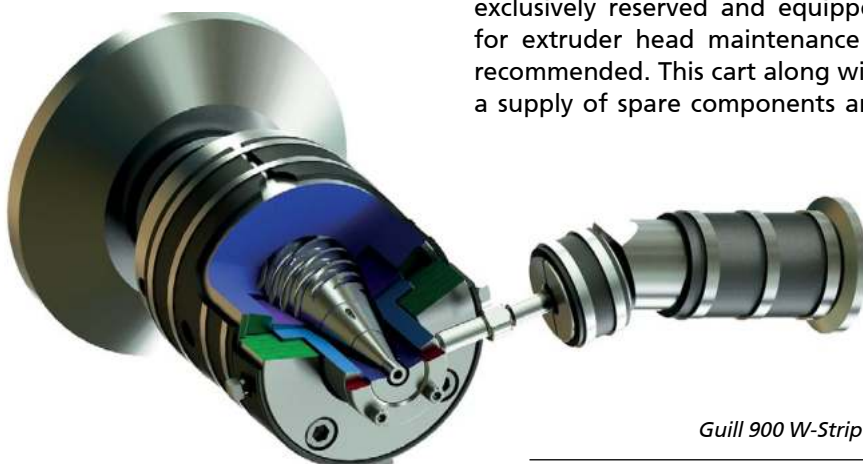

*Guill 900 W-Stripe*

aids available, including overhead hoists, hydraulic lifts, etc. In most situations, the head and tooling will still be at elevated temperatures, therefore lined gloves are needed when handling. Today, tubing manufacturers compete with companies all over the world. To be a successful and profitable company, quality and efficiency are essential. This is especially true in extrusion, where material costs are usually much higher than labor costs. Like a racing car stuck in the pit, many extruders sit idle because of poor or damaged tooling, plus excess maintenance time. Overhead costs add up and losing money is the result. Some start up quickly and make scrap, whereas others start up and run a product oversized to hold minimum tolerance. They waste 10% to 20% of the material, which can run from 50% to 90% of the product cost. The tooling supplier goes to great lengths so that tips and dies are machined to a determined specification, ensuring perfect concentricity and alignment. The material is then distributed in the proper location as part of the finished product.

### Understanding Maintenance Procedures: Get Organized Before You Start

Example 1: In this example, with an improperly centered tool, a calculated out-of-tolerance area of 0.059 in<sup>2</sup> (38 mm<sup>2</sup>) was derived. When the two surface areas were compared, the calculated material waste was 11.8% of the finished product. The formula is  $\% \text{ wall} = \frac{\text{min. wall thickness}}{\text{max. wall thickness}} \times 100$ . Example 2: Alternatively, if the % wall can be increased from 80% to 95%, a savings of about 12% of total cost can result. Savings will vary depending on the designs, of course.

Get help for heavy parts and awkward situations. Surfaces and edges are hard and therefore somewhat brittle, so dropping a part or striking parts together can result in damage. Store your tools properly in a dry, clean area – a dedicated spot for each tool is best. These areas should have soft surfaces and each instrument should be covered af-

ter cleaning. Also, tools should be segregated so that they do not come into contact with each other. And tools and all instruments should be cleaned thoroughly before storage.

For disassembly of tools, it is imperative to use purpose-built tooling to facilitate disassembly. These should be available from your supplier. If they are not, consult with a reputable tooling house for replacements. The cost of these tools is easily offset by potential damages, frequently caused by improper equipment such as hammers and drifts. Follow the guidelines outlined in your operator's manual. Individual tools may have specific recommendations, so contact your supplier if anything is unclear. Your supplier understands that optimum performance relies on proper care and maintenance. Here are some useful tips: 1.) Clean your equipment while it is still hot as the residue is easier to remove. It helps to remove and clean one piece of tooling at a time in order to maintain elevated temperatures. 2.) When cleaning a dual compound crosshead, (plastic and rubber) clean the plastic tooling first; the rubber second. 3.) Never use steel tools such as scrapers or screwdrivers because these can scratch and mar the tooling. 4.) Do not use open flames because this generates excessive heat especially in thin sections, which can affect hardness, concentricity and tolerances of components. Recommended cleaning tools and materials include: a.) Brass pliers to grip material and aid in pulling; b.) Brass scrapers available in different widths for cleaning flat exposed surfaces; c.) Brass bristle tube brushes that are available in diameters from 1/16" to 1" in 1/16" increments (ideal for cleaning holes and recesses); d.) Brass rods – different diameter rods are good for pushing material out of flow holes; e.) Copper gauze for cleaning and polishing exposed round or

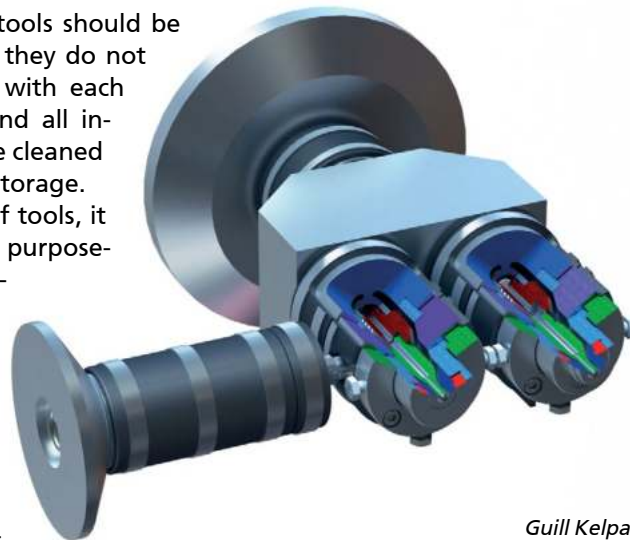

Guill Kelpac

conical surfaces; f.) Copper knives for removing residue from recesses and other hard-to-reach areas. Also, polishing compound restores polished surfaces; g.) Compressed air, which is more effective for releasing plastic, but also aids in rubber removal. Be careful not to force debris into recesses with compressed air; h.) Cleaning solutions may be useful, so remember to use fresh, clean rags (used rags often have metal chips embedded in them, which may scratch polished surfaces); i.) Cleaning oven – for plastic only. Follow manufacturer's recommendations. If no temperatures are specified do not exceed 850 degrees F (454 degrees C). Don't quench tooling to cool, as this could affect tooling hardness, concentricity and tolerances. j.) Purging compounds – several are offered to purge the extruder screw/barrel of residual polymer and rubber compounds.

### Removing Excess Material for Optimum Machining Efficiency

Clean parts are critical to extrusion tooling performance and quality manufacturing. This is especially true for the sealing and locating surfaces – that control uniformity of the production process. For general maintenance of the tools, before storage or tooling changeover, a thorough cleaning and removal of the excess material assures the precision machining alignments required to produce end products to the precise tolerances. Equip-



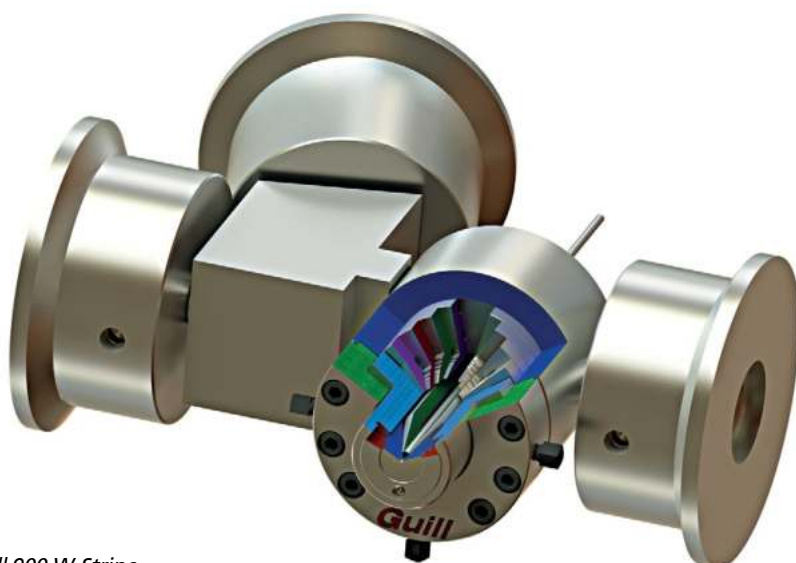

Guill 900 W-Stripe

ment should be cleaned while it is still hot, since residual polymer and rubber will be easier to remove. Be sure to follow all MSDS recommendations when heating the tooling. Thermal gloves are used to protect the hands from the heated tooling surfaces. A brass scraper, as well as a brass or copper wool cleaning cloth are recommended because they are soft enough not to scratch the surface.

### Make Tool Cleaning Easier

The quickest way to remove the die is to employ the pressure of the extruder to push it out. Clean the body by using an air compressor and brass pliers so that the material cools down which increases the melt strength, making it into one-lump versus an elastic, gummy-like substance that is harder to remove. Cleaning the body feed port using compressed air and brass pliers to simultaneously cool and remove the excess residue from the feed ports. This procedure is followed by brushing with a round brass brush that polishes the surface. The flow area of the 2" (51 mm) flange adapter should be cleaned by carefully using a brass brush.

Examine all surfaces for any irregularities such as burrs and scratches since these must be repaired before the head is reassembled. Most

manufacturers recommend using a hand polishing stone to remove the offending burr. Follow stoning with a light application of 600-grit emery cloth if necessary, but avoid rounding edges that are intended to be sharp. Flat sealing surfaces can also be cleaned using a stone, followed by a 600-grit emery cloth. Place the cloth on a clean, flat surface, preferably a surface plate, then apply friction in a circular hand motion until the area is clean and even. The parts in question should all be hardened steel alloys and will not be adversely affected using these methods. Inconel, monel and Hastalloy® are typically not heat-treated, requiring special care and handling to avoid any damage.

### Don't Overlook Repairs

Tooling maintenance helps ensure a quality extruded product – one that meets dimensional specifications, maintains the specified minimum tolerance and is economically produced. Dirty, neglected and improperly adjusted tools contribute to excessive compound applications, which in turn complicate maintenance of minimum thickness tolerance. Excess material results in unnecessary costs and these directly affect the profitability of your company and the relationships with your customers.

### The Important Final Step – Reassembly

Working from your dedicated tool cart, follow the manufacturer's instructions for reassembly. Give each component a final wipe down with a clean rag before installing. Even the smallest amount of grit, dirt and residual material must always be removed. Use mechanical or manual assistance for heavy and awkward components to avoid unnecessary mishaps. Reapply anti seize compound to all fasteners if required. Tighten fasteners to manufacturer's recommended specifications as well as in the recommended sequence. This fastening sequence should be specified in the manual and is generally in a star pattern. Tighten gradually until the proper torque is achieved to prevent distortion of the tooling. One of a die manufacturer's main goals is to form a concentric cone as quickly and accurately as possible in the primary section of the die – when the extrudate first emerges from the die's distribution capillaries. A properly designed and manufactured die has even distribution close to the extrudate entrance point, but this effort is negated once the die is adjusted, shifting the extrudate off to one side. An eccentric cone is formed in the primary area, and a concentric cone exists at only one point in the process, rather than a smooth, continuous flow path with decreasing volume. A properly manufactured and aligned extruded head, along with well-maintained tooling should require little or no adjustment. Another adverse affect of unnecessary die adjustment is the stress introduced to the extrudate caused by unbalanced flow. The net effect is the final product retains memory of this imbalance and unpredictable die swell occurs.

Guill Tool & Engineering Co., Inc.  
10 Pike Street, West Warwick,  
RI 02893, USA  
www.Guill.com

# Extrusion System for ABS Foam Core Pipes

*The foaming of thermoplastics is a process known to the state of the art, in which a fundamental distinction is made between chemical and physical foaming. This article deals with chemical foaming, in which it is possible to achieve dense reductions of up to 40 % with the aid of blowing agents in powder or granules form.*

Applications can be found in profile, sheet and pipe extrusion. Foam core pipes are used in the pipe extrusion sector. PVC foam core pipes have a market share of almost 100% in the segment of non-pressurized drainage pipes with a diameter of up to 400 mm.

Applications for PE, PP and ABS-foamed pipes exist on the market for non-PVC pipes, albeit to a much lesser extent. Foamed pipes have a lower overall density, which leads to weight and cost savings. This article deals with the extrusion of ABS foam core pipes.

ABS pipes are used as a PVC replacement in certain markets as they have high impact strength, even at lower temperatures, and are more chemically resistant.

## Extruders

With regard to the extrusion of ABS, it should be noted that pre-drying at 80 °C for four hours with dried air is essential, regardless of the type of extrusion. In sheet extrusion, a variant with a smooth feed zone and degassing zone in the barrel has proven itself, especially for higher outputs of well over 1,000 kg/h. However, this process has certain disadvantages. How-



ever, the process has certain disadvantages. For example, degassing extruders require a melt pump and the disposal of residues from the degassing zone often proves to be difficult. Extruders without degassing are therefore used for outputs of up to 800 kg/h, whereby raw material manufacturers recommend the use

of extruder barrels with a smooth feed zone. One disadvantage of these barrels, however, is their poor feed behavior with all styrene polymers, including ABS, which leads to fluctuations in pump and output behavior.

CONEXTRU, on the other hand, takes a different approach and uses grooved feed zones. These are stable and do not exhibit any feed fluctuations.

The high coefficient of friction between the screw and the grooved feed zone results in a high specific output (kg/RPM). The resulting forces are reduced by reducing the compression in the infeed compared to PE and warming up the grooved bushing. For this purpose, an external temperature control unit is used, which works with silicone oil and enables temperatures of up to 200°C. Although such high temperatures are possible, they are not absolutely necessary and it is usual to operate the feed zone at 80 °C. The necessary pre-drying at 80 °C heats

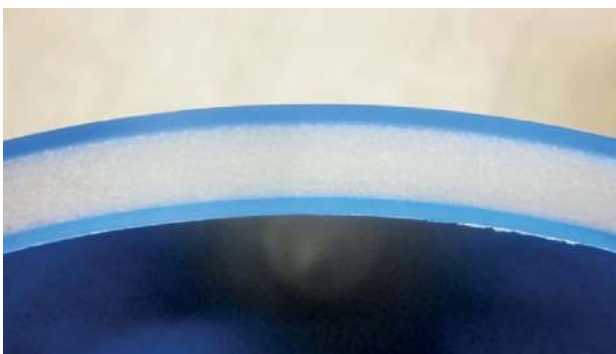





the material and utilizes the energy stored in the material. This energy can then be used to reduce the motor power. Furthermore, the enthalpy of ABS (shear energy required to place the material) is significantly lower compared to PE.

The preheating and the lower shear energy result in a significantly lower installed motor power compared to PE or PP. For this reason, it would make sense to design a special extruder for ABS instead of using a standard PE/PP extruder for ABS extrusion. The screw geometries are similar to the PE design, i.e. there is grooved feed, transmission, barrier, maddock and mixing. The shear energy output of an ABS screw is approx. 30 % lower than that of a PE screw and two specially designed extruders are used for the 3-layer extrusion of ABS: C 45 37 to 250 kg/h for the inner and outer layers and C 60 37 to 450 kg/h for the middle layer. Both extruders are equipped with a temperature-controlled feed zone and gravimetric dosing for output control or weight per meter control.

The blowing agent is metered volumetrically via a metering unit attached directly to the extruder, and ABS foams well if the right blowing agent is selected, i.e. a short decomposition time at low temperatures of around 170 °C is required because the dwell time in the extruder or pipe head is short due to the low volume. The blowing agent can be added volumetrically or gravimetrically as micro-granules.

The foaming of ABS is only successful if the blowing agent is correctly selected. A short decomposition time at low temperatures of around 170 °C is required, as the

residence time in the extruder or pipe head is short due to the low volume. Mixing is effective and is further enhanced by a more intensive mixing section at the end of the screw. The diagram illustrates the output and energy consumption at a back pressure of 200 bar.

### Pipe head

In the past, mandrel holder tools, as used in PVC extrusion, were generally used. However, these have the disadvantage of a high volume and a long dwell time. In addition, the web marks are usually visible and impair the quality of the cross-section. Furthermore, ABS is thermally sensitive, which can easily lead to oxidation of the butadiene content and a significant reduction in spiral mandrel manifolds are pre-

ferred, which have a low volume, good melt distribution properties and the possibility of extracting the internal air in the pipe through the pipe head. Effective internal pipe cooling is not required, only the reduction of the internal temperatures in the pipe is necessary to reduce the possibility of oxidation, which would be visible through brown discoloration. ABS has another special property: the flow property, i.e. the flow of the melt, reacts strongly to the surface temperature of the flow channel.

Air currents and temperature inhomogeneity lead to a change in flow around the circumference. For this reason, it is necessary to use insulated heating tapes to prevent cooling from the outside and to ensure uniform temperature distribution. The pressure build-up of ABS in

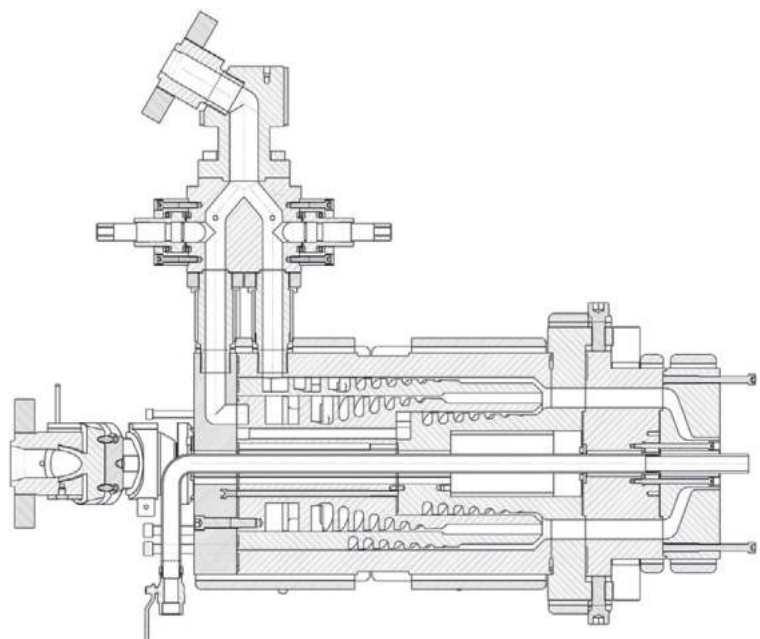



called Y-block. As the pressures of the inner manifold differ from the pressure of the outer manifold, this must be taken into account in the Y-block and is corrected via an orifice plate. In this way, the pressure build-up and layer thickness of both layers are equalized.

**Die design**

When designing the nozzle, it must be taken into account that a weight change of approx. 20 to 40 % occurs during foaming. This percentage must also be taken into account when designing the nozzle in order to ensure that the melt foams by this percentage after leaving the nozzle and that the diameter is calibrated without upsetting or undercutting. To ensure free foaming, a certain distance between the nozzle and the calibration is required, as the foaming process does not take place in the nozzle, but only when the melt leaves the nozzle and the pressure is removed. As a result, the nozzle diameter must be reduced by the percentage of foaming to be expected, and this also applies to the

wall thickness. For a foam density of 20 %, a reduction of the nozzle and the gap by 20 % each is therefore required.

**Weight and cost saving**

It should be noted that the calculation for weight and cost savings is well known from PVC foam core pipe extrusion and is merely adopted here. In this example, a density reduction of 40 % of the middle layer is assumed. This results in an overall density of

0,8 kg/dm<sup>3</sup> if the foamed layer accounts for 60 % and the wall thickness remains the same. This results in a weight reduction of app. 25 %. (Tabelle)

This also reduces the amount of material used, which is reflected in the lower weight per meter costs and an increase in the length of pipe produced.

*By J. Dobrowsky*

CONEXTRU

Klosterstarsse 19, 3011 Irenental, Austria

► Dobrowsky.j@conextru.eu

spiral mandrel manifolds is low and the melt distribution is good.

A triple spiral mandrel manifold is used for processing foam core pipes. The foamed middle layer usually covers 60 percent of the entire cross-section. A smaller extruder is used for the two layers "compact inside" and "compact outside", and the distribution from the inside to the outside takes place in the so-

	compact pipe	3 layer pipe	Outer Layer kompakt	Middle layer foamed	Inner Layer kompakt	
Outside Diameter	160	160	160,0	157,3	144,7	Diameter of layer
Wall Thickness	9,00	9,00	1,4	6,3	1,4	Thickness of layer
Tolerance W.T.						
Density kg/dm <sup>3</sup>	1,05	0,76	1,05	0,63	1,05	Density of layer
Meterweight (kg/m)	4,48	3,23	0,71	1,88	0,64	Meterweight of layer
Weightsaving		28%				
Metercost	8,97	6,49	1,41	3,80	1,28	Cost of 1 meter each layer
Costsaving		28%				

► Engineered to perform.  
**Maximum film performance at full recyclability.**

Full recyclability, excellent transparency and impressive mechanical properties: Ultra-thin MDO-PE and MDO-PP film produced on SML's latest generation of cast film lines open new opportunities to manufacturers and form the technical basis for the mono-material packaging solutions of tomorrow.



www.sml.at



**SML**  
 EXTRUSION LINES – ENGINEERED TO PERFORM ►

# Cost Savings in the Production of Pipes

*“We studied machine time, manpower costs and scrap costs, and the return on our investment was about 3 to 4 months. The solution provided by Jorge Lage at Zumbach reduced our previous process for acquiring an accurate measurement from about 2 hours down to 5 minutes,” Todd Clarke, Production Manager at SWM International.*

**S**WM International, based in Richland, Philadelphia, USA, is a specialist in the manufacturing of polypropylene and HDPE tubes and pipes. The company relies on the UMAC® R ultrasonic measuring system from Zumbach Electronic to maximise their manufacturing efficiencies, whilst providing significant cost savings through reduced waste materials.

The UMAC® ultrasonic measuring system is a state-of-the-art solution which measures wall thickness, eccentricity, and concentricity of tubes and pipes with unparalleled precision, with the ability to handle product diameters ranging from 0.2mm up to 400mm. The solution has been developed with a range of different transducer holders that make the UMAC® exceptionally versatile. Integrated into the UMAC® is the System on a Chip (SoC) unit called UMAC® CI. This expands capabilities with recipe-based operation (without requirement of manual setting manipulations based on the echo signal display), provides a 1kHz sample rate and an integrated webserver. The UMAC® R system provides fixed transducer holders, available in configurations for 4, 6 or 8 measuring points. The ring-shaped transducer mounting fixture is configured for installation into an existing vacuum tank and integrates seamlessly into existing production lines.

SWM embarked upon a transformative journey with Zumbach Electronic to address a critical challenge in their polypropylene and HDPE tube and pipe production facility in Richland, Philadelphia. The traditional method of measuring products off-line with calipers was not only time-consuming but also resulted in significant material waste and production down-time, driving up production costs, and the implementation of the UMAC® R marked a turning point for SWM. The solution, provided by Jorge Lage at Zumbach Electronic Corp. offered fast eccentricity testing capabilities which

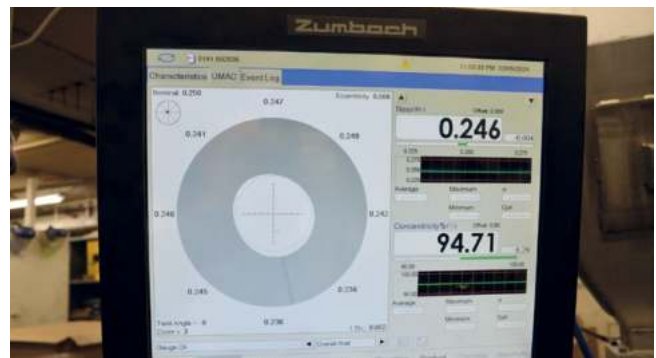

Zumbach UMAC® R Wall Thickness Visualisation

significantly reduced start-up times and facilitated quicker changeovers. Real-time feedback enabled immediate adjustments, ensuring consistent product quality and drastically reduced material waste.

In its first year alone, the UMAC® R system delivered an impressive \$40,000 in scrap savings. SWM International's collaboration with Zumbach Electronic exemplifies how innovative technology can drive significant improvements in manufacturing processes. By embracing the UMAC® R measuring solution, SWM has not only enhanced its production efficiency, but also reinforced its dedication to quality and sustainability as well as customer satisfaction across the diverse industries it serves. The results were nothing short of remarkable.

In a world where precision and efficiency are key, SWM International's strategic adoption of Zumbach's UMAC® R stands as a testament to the power of innovation in achieving operational excellence.

**ZUMBACH Electronic AG**  
P.O. Box CH-2552 Orpund, Switzerland  
[www.zumbach.com](http://www.zumbach.com)



Vacuum Tank at SWM International's Richland, PA production facility



SWM International's large diameter piping extrusion



# Success with Machined Thermoformed Parts and Fully Assembled Components

*The swissplast group has quickly grown by focusing on high-quality thermoformed parts and a strong emphasis on service, quality, and delivery speed. In addition to thermoforming itself, key success factors include the machining and assembly of parts. The company relies on machining centers from HG GRIMME SysTech, among others, due to their quality, precision, and dynamics. The similar mentality of the two family-owned businesses also plays a role, as demonstrated at the Gotha site.*

“We combine comprehensive service with a high level of machining and assembly – and all of this at high speed,” summarizes Ninyan Bieri, COO of the swissplast group, the company’s promise. The company, led by his father Barac S. Bieri, specializes in functional, design-oriented components and workpiece carriers made of all types of thermoplastic materials. Its range of services extends from design and thermoforming to the machining of parts and the assembly of entire components.

This includes many body and interior parts, some in Class-A quality, for motorhomes, semi-trailers, buses, and trains, among others. Customers also come from plant and mechanical engineering, the construction and packaging industries, medical technology, and heating system manufacturing. For the latter, swissplast supplies, for example, covers for heat pumps and boilers.

“The machining of thermoformed parts is a very important part of our range of services,” emphasizes Bieri. The group manufactures trays and workpiece carriers as well as technical parts in roughly equal proportions. Almost 90 percent of the latter are milled. “Since milling and drilling play such a large role, we at swissplast have also relied on machining centers from HG GRIMME SysTech for many years.”



*Ninyan Bieri, COO swissplast group (left), and Martin Sombrowski, Sales Manager Europe at HG GRIMME SysTech (All photos: HG GRIMME SysTech)*

## Large and Voluminous Thermoformed Parts Manufactured in Gotha

The approximately 200 employees of the Swiss group of companies are spread across four locations: in Gotha, Thuringia; Diedorf and Ichenhausen in Bavaria; and at the Swiss company headquarters in Sargans. Although the legally independent companies have different strengths and profiles, they work closely together. The focus is on thermoforming pre-configured purchased sheet material. It consists mainly of acrylonitrile butadiene styrene copolymer (ABS), polymethyl methacrylate (PMMA), and polystyrene (PS) – if possible, with a high recycled content – and is processed in batch sizes between 10 and 250 pieces. Only in the Diedorf plant is the focus on film production for technical packaging.



*In use since 2018: The RT-F 1400 5-axis CNC rotary table milling machine for small workpieces*



*The 5-axis CNC machining center G-S-F(24-13)/B in gantry design was added in 2020*



*Around ninety percent of the technical parts that swissplast thermoforms in Gotha end up being milled*

In Gotha, sheets up to 2,500 x 1,300 x 800 mm in size with material thicknesses between 2 and 13 mm can be processed; pure thermoforming would even be possible up to 3,000 x 2,000 x 1,000 mm.

The approximately 25 employees at the site, some of whom work in two shifts, primarily manufacture larger parts, including voluminous side wall panels or gas tank doors for motorhomes. These are then milled to create cutouts, for example, for windows or vents, and holes are drilled. This is followed by assembly, during which ventilation grilles and entire lighting and locking systems, among other things, are mounted, bonded, and ultrasonically welded.

### Premium CNC Maschines from Bavaria

Across the various locations, the thermoforming company has a series of 5-axis CNC milling machines from the Bavarian premium manufacturer in operation. In

*Since 2020, swissplast has also been milling larger parts on the 5-axis CNS portal milling machine P-S-F(25-13)*



Gotha, three different models are currently in use. In 2018, swissplast acquired an RT-F 1400 rotary table system, followed two years later by a single-table gantry system and a machine in gantry design.

The highly compact rotary table system is particularly designed for workpieces with cubic dimensions in X/Y/Z of 1,000 x 800 x 400 mm and a maximum total weight of 200 kg. swissplast primarily uses this machine to produce small covers and panels that are completely machined in a single clamping.

In the RT-F 1400, the rotary table performs the C-axis movement, allowing the workpieces to be milled with exceptional dynamics and high precision. High productivity is also achieved through minimal traversing movements and a water-cooled milling spindle with two shaft ends, each of which can accommodate a milling tool. With a

*The portal milling machine is used as a single-table system, but it would also be possible to divide the work area or double it with an additional table and then manufacture even more productively in tandem operation*





simple rotation to the other shaft end, the spindle can use a second tool.

The closed design with a protective cabin prevents chips from leaving the cabin. Thanks to two manually opening doors, the operator has easy access to the workpiece. The operator also benefits from simple handling via the integrated, swiveling control panel with a NUM controller.

### Dynamics and Agility

swissplast was very satisfied with the rotary table system and needed machines for its continuous growth, HG GRIMME SysTech was able to deliver two more CNC machining centers in 2020. Both milling machines are designed for significantly larger and heavier parts. The G-S-E(24-13)/B in gantry design is conceived for workpieces with external dimensions up to 2,400 x 1,300 x 600 mm (X/Y/Z), while the portal machine P-S-F(25-13) offers 100 mm more space in the X-axis with otherwise identical cubic dimensions. Their tables can be loaded with up to 800 kg.

"We quickly realized," says Ninyan Bieri, "that HG GRIMME SysTech is a reliable partner, very easy to reach, and quick to react. Moreover, like us, they are a family-owned company and correspondingly dynamic."

Martin Sombrowski, Sales Manager Europe at the Bavarian company, agrees and cites an example: "Many appreciate that our service always responds very quickly to inquiries. We are also proud that many of our machining centers are ready for operation and producing chips just two days after delivery."

COO Bieri also places great value on the agility and flexibility of his group of companies: "We act and grow quickly. We live our motto 'swissplast – easy to deal with.' If necessary, we can also handle projects with thirty new tools in one go and in an incomparable time."

### Highly Productive CNC Machining Centers

He cites the focus on thermoforming, the young and very flexible team, and the modern machinery as factors for success. Moreover, the thermoforming systems at the locations are usually available in duplicate, and the machining centers are highly productive. "Therefore, we can handle very urgent orders at two locations simultaneously if needed. Our employees go along with this and work wherever they are needed," Bieri raves.

Since 2020, the newly added CNC machining centers have also contributed to the rapid machining of parts.

Like all systems from HG GRIMME SysTech, they score points with a particularly solid design that absorbs vibrations to the greatest possible extent. The result is impressive, finds Sales Manager Sombrowski: "With this, we achieve high precision in milling and drilling with positioning accuracies of  $\pm 0.045$  mm. This leads to excellent surface qualities."



*In addition to post-processing, the assembly of parts into modules also plays a major role*

In addition, the machines feature powerful high-frequency milling spindles with up to 15 kW of power in continuous operation (S6). These deliver speeds of up to 36,000 rpm on the portal machine. Dynamic accelerations and cutting speeds also ensure highly productive high-speed machining.

### Prepared for the Future

The machining centers are also prepared for further growth at swissplast: Although they are currently in use as single-table machines in Gotha, there is the option for the future to divide the working area and then produce even more productively in tandem operation. The machines can also be easily adapted to changing requirements.

In addition to a wide range of accessories, numerous options are available for individual configuration. These include, among others, magazines for additional tools, measuring probes for breakage and length control, workpiece measuring systems, special packages for dust-free CFRP machining, and an alternative Siemens control system.

Ninyan Bieri's conclusion on the machining centers from HG GRIMME SysTech: "We are satisfied with the quality of the machines and also with the price-performance ratio."

*The Author*

*F. Stephan Auch, freelance technical journalist, Nuremberg/Germany*

HG GRIMME SysTech GmbH  
Osterweg 23, 86879 Wiedergeltingen, Germany  
[www.hg-grimme.de/en/home/](http://www.hg-grimme.de/en/home/)



# Think big: a modern line for the production of large-diameter polyethylene pipes up to 1600 mm

*Tecnomatic announced the supply of its latest high-capacity extrusion line for polyethylene (PE) pipes, specifically designed for pipes with diameters up to 1600 mm, to one of Europe's most distinguished pipe manufacturers. This state-of-the-art line brings together Tecnomatic's cutting-edge Zeus EVO series gearless extruders and the innovative Venus 1600 die-head, designed to meet the demands of large-diameter, thick-walled pipe production with unparalleled precision and output efficiency.*

At the heart of this advanced line are two Zeus EVO series extruders, engineered to deliver outstanding power and efficiency. The updated screw design improves material flow plasticization, and reduces energy consumption. The new optimized spiral feeding bush ensures a smooth and consistent material feed, minimizing fluctuations and enhancing homogeneity, a critical factor for producing large-diameter pipes with uniform wall thickness. Together, the extruders deliver a cumulative output of almost 2,000 kg/h, which enables high-speed, essential for the increasingly demanding market requirements in large-diameter pipe production.

Each extruder is equipped with a gravimetric dosing system featuring three separate components for ultra-precise dosing and weight control. This gravimetric system ensures that material feed and pipe weight are tightly regulated, allowing for exceptional meter weight accuracy across each run. The precision dosing plays a critical role in maintaining product consistency, particularly vital in producing large-diameter pipes, where wall uniformity is key to meeting quality and performance standards.



## Venus 1600 Die-Head: Advanced Centring for Wall Thickness Consistency

The Tecnomatic line includes the re-designed Venus 1600 double-spiral die-head, which is central to producing large-diameter pipes with uniform wall thickness. The Venus 1600 is engineered specifically for pipes of this calibre and integrates innovative mechanical and thermal centring solutions, ensuring optimal thickness uniformity even with very high wall dimensions.



The double-spiral design of the Venus 1600 promotes even material flow, reducing the risk of thickness inconsistencies often associated with large pipe diameters. The centring system provides a two-fold approach: mechanical adjustments align the die-head for correct positioning, while thermal control ensures temperature stability within the die. This combination allows for precise, on-the-fly adjustments to maintain pipe centring and thickness uniformity under varying production conditions.

Achieving high output for large-diameter pipes requires an exceptional cooling and vacuum system, which Tecnomatic has addressed with a vacuum length of over 20 meters. This extended vacuum zone provides rapid and effective cooling, essential for maintaining pipe shape and structural integrity during high-speed

production. The optimized vacuum design helps the line achieve superior production rates without compromising on quality.

Tecnomatic's line is complemented by premium downstream equipment, supplied by a renowned Italian manufacturer known for quality and precision in pipe handling systems. The downstream components include a 12 caterpillars haul-off and a knife cutting unit that work in sync with the lines' output capacity, ensuring smooth and precise handling of pipes throughout the production process. This high-quality downstream setup minimizes the risk of deformation and maintains the pipe's roundness and clean cutting finish, crucial for large-diameter applications where dimensional accuracy and surface quality are non-negotiable.

Tecnomatic's advanced PE pipe extrusion line, combining the EVO Zeus extruders with a high-precision die-head and robust downstream equipment, provides a comprehensive, future-proof solution for large-diameter pipe production. With innovations in energy efficiency, material control, and throughput stability, this line is set to redefine the standards of cost-effective, high-quality PE pipe production in Europe.

Tecnomatic Srl  
Bergamo, Italy

► [Tecnomatic srl.net](http://Tecnomatic srl.net)





# Collaboration – *Production of Stretch Film that Incorporates Recycled Content*

*As interest in recycling has grown in importance in recent years, a wide variety of plastic waste streams are being evaluated for their recyclability potential. Important criteria are the expected annual volume, potential contamination and the material composition of the streams.*

LDPE/LLDPE film has existing collection systems in many European countries that have been in place for many years to provide this type of material for recycling. As markets demand recycled content in a broader range of applications, a challenge is to produce clear shrink, stretch or blown film that maintains properties while incorporating recycled content.

In this context, new capacities have been built in Europe and worldwide or existing plants have been retrofitted with improved sorting, washing steps or additional melt filtration systems in order to be able to offer high-quality polyethylene (rPE) streams for recycling. However, even LDPE/LLDPE that has undergone extensive mechanical processing, can be difficult to convert into new film on conventional production lines, which is why the companies Colines, ExxonMobil Signature Polymers and Gneuss have joined forces in a development project to develop a viable film production process with potential cost savings.



*Production line with Gneuss RSFgenius filtration system in Europe*

In particular, the so-called gels and black dots are disruptive factors that could be minimized with the appropriate materials from ExxonMobil Signature Polymers and a pressure-constant screen changer from Gneuss on a highly flexible cast film line from Colines.

ExxonMobil Signature Polymers's technical experts have conducted trials using PCR material (Post Consumer Recycle) derived from stretch film in combination with Exceed Tough m 3812 high performance polyethylene and observed a reduction in the size of the larger polymer gels.

"With most of the commercial PCR grades available on the European market today, extrusion lines often cannot run continuously. Continuous filtration can help to run extrusion lines for longer production periods.

*RSFgenius filtration system in operation at Colines' technical center*



Filtration removes a significant proportion of the impurities present in the melt, but not all the gels," says Bart Lauwers, Principal Extrusion Customer & Application Development at ExxonMobil Technology Group.

Nevertheless, the project has demonstrated quality and process consistency. All tests carried out demonstrated the ability to consistently produce film that incorporated 30% PCR content for automatic use with a consistency of 180 to 200% without the need to stop the line, except for routine operations unrelated to recycle use (e.g. lip die cleaning, chill roll cleaning, resin or format changes).

A key component in this process was the patented Gneuss RSFgenius self-cleaning screen changer. This fully automatic filtration system renewed the screen surface with no measurable pressure fluctuations and can be adapted to the material in question, with screen

finenesses typically ranging from 30 - 75µm, even during full operation.

Colines is a renowned manufacturer of cast and blown film lines based in Novara, Italy. Colines has demonstrated exceptional flexibility in meeting the individual needs of its customers. Not only with the full integration of Gneuss screen changers, but also in terms of fully customizable line set-ups for the production of any type of film.

The collaboration between Colines, Gneuss and ExxonMobil Signature Polymers has already led to the creation of several large-scale production lines specifically dedicated to recycled content incorporation with many more in progress for various global markets.

Gneuss Kunststofftechnik GmbH

Moenichhusen 42, 32549 Bad Oeynhausen, Germany

www.gneuss.com

# One-Stop Solution for Data-Driven Decisions

*When it comes to high-performance extrusion lines, SML is one of the technological leaders and has been in the market for extrusion machines for more than 25 years. When developing digital services for its lines, SML adheres to the same "all in-house"-approach which it applies to all of its other core competencies.*

"For several years now "industry 4.0" has been a popular buzzword but the underlying question is always how the companies that operate our machines can benefit from the rapid developments being accomplished in the digital sector," Christoph Strasser, Team Leader of SML's Digital Business Unit, says. Like all of its other core competencies, such as mechanical engineering, electrical design or automation, SML makes sure to keep the development of digital solutions strictly in-house. Close co-operation among the different departments, all located at SML's headquarters, supports the creation of coherent extrusion concepts with perfectly harmonised digital solutions.

## bitWise: Analysing data – increasing productivity

Bitwise, the data generation and analysis tool, is at the heart of SML's digital activities. Today it



is used in more than 200 extrusion lines around the world. "bitWise enables the comprehensive collection, processing, analysis and transmission of manufacturing data – in an extraordinarily fast and easy

manner. The process knowledge bitWise generates, helps to continuously optimise both the manufacturing processes and the product quality," Christoph Strasser continues. Its main purposes are to

streamline workflows, identify and solve problems pertaining to quality, analyse machine defects – and, above all, to increase machine productivity.

The most popular areas of application include

- The real-time monitoring of various process-relevant or quality-relevant production values, such as the melt temperature, extruder pressure or coating weight – with an alarm function, if certain values deviate
- Digital shift books for the systematic documentation of all events during a shift
- The bitWise Track and Trace function: all of the data generated during production can be assigned to a specific, finished film roll, for example via a QR code. This presents new opportunities for quality control and product enhancement.

### Flexible dashboards for operators and CEOs

bitWise enables data-driven decision making, regardless of the organisational level – execution, planning or enterprise. It supports the machine operators, the maintenance team, shift leaders, quality managers and not least the CEO / management. To simplify day-to-day work, the bitWise dashboard can be customised to suit the specific field of activity of the user. Since bitWise is per se a web-based solution, remote access, i.e. via a tablet or a personal computer is possible, provided that the company can cater to the system requirements.

### SML takes care of bitWise

bitWise was created by a highly skilled team of seven full-stack software developers and data scientists



with a wealth of experience in automation and data analytics who now continue to develop it on a regular basis. The fact that bitWise is made 100% at SML generates an array of benefits. Above all, that SML takes care of it in a comprehensive way:

- Automatic updates from SML
- SML observes the components used and closes security issues
- SML monitors the local bitWise server attached to the extrusion lines, customers are notified by SML before problems occur.
- New features can be added automatically
- Personal support and assistance

### Open system – interconnectivity

One vital characteristic of bitWise is its system openness: The data exchange is based on open standards such as HTML and OPC-UA. So bitWise provides full interconnectivity for the comprehensive exchange of data between the extrusion line and connected machine auxiliaries, such as the inspection system, cloud-based solutions or the ERP.

SML Maschinengesellschaft mbH  
Gewerbepark Ost 32,  
4846 Redlham, Austria  
→ [www.sml.at](http://www.sml.at)



## TR3515PE MSR

**Automatic coiler** consisting of **one reel**, **1 or 2 automatic strapping head** for safer packaging operation and **Round Pipe System on board**. Designed to obtain **perfect coiling** of **PE pressure pipes** and **GAS pipes**.





# Sustainability Report Presented

*An opportunity to present the company from the point of view of sustainability. It confirms the commitment in the transition towards an economy increasingly focused on reducing environmental impact, generating value and improving the community welfare by synergically combining technology, innovation and human assets.*



In 2024 Moretto achieved an important goal: the publication of the Sustainability Report. Covering the calendar year 2023, it is based on ESG (Environmental, Social and Governance) criteria and in compliance with the international GRI (Global Reporting Initiative) standards. The report confirms the company's formal and structured commitment to environmental, social and economic sustainability.

"For us, the Sustainability Report is a way of dialogue, to communicate what we do and to measure ourselves in new challenges in the socio-environmental field. A commitment that involves the whole company in an active and motivated way, a starting point that will lead us to set new ambitious goals for the future, underlining our orientation towards

continuous improvement," states Renato Moretto, founder and president of the company. The voluntary publication, ahead of regulatory requirements, underlines the desire to implement transparent communication making known choices and actions aimed at minimizing environmental impact, generating value and improving the community well-being.

## Product development as a key to sustainable technological transformation

For Moretto, sustainability is not a trend, but a value that has characterized the company and the product throughout its history. One of Moretto strategic development



drivers has always been the energy efficiency of its products. A path in which the company's commitment, the customers' needs and the development of the dedicated technology have combined perfectly leading the production of innovative solutions in line with the cur-



rent economic context. Electricity represents one of the highest costs in the manufacturing industry and solutions capable of significantly reducing them represents an essential competitive advantage.

Moretto offers several patented automations that stand out for their energy efficiency: the OTX drying hopper; the Hyper Flow turbocompressors; all the dryers that adopt the exclusive Moretto "X Technology" and many other products that have contributed to the company's success over the years.

### **The environment, an asset to be preserved**

Looking at the environmental factor, the company promotes the efficient management and use of resources within its production processes and along its value chain.

The only use of energy from renewable sources in our factories represents one of the initiatives already implemented. The 100% CLEAN ENERGY brand identifies the origin of electricity from renewable sources, produced by the hydroelectric stations located in the Italian Dolomites, whose generation does not cause emissions of gases responsible for the greenhouse effect.

In addition, the achievement of the UNI EN ISO 50001 certification confirms the adoption of an energy management system compliant with international best practices that ensures less waste and a better use of resources. Minimising the ecological footprint of its business through energy efficiency, the reduction of greenhouse gas emissions, the use of LED lighting in factories, the sustainable management of resources and the promotion of the circular



*Drying installation*

economy are synergic actions implemented with foresight that have allowed Moretto to reduce its overall consumption by 13% in 2023, the reporting year, compared to 2022.

### **Value-based social responsibility and governance**

The more the company progresses in digital evolution and automation, the more the contribution of the individual is recognised. An integral part of the corporate policy is the respect for the individual, the continuous improvement of safety and the focus on the welfare of its employees and collaborators. Resource management is conducted with the aim of enhancing each profile, trying to guarantee an increase in technical and professional skills, applying the principle of inclusion and respect for the value of diversity.

Furthermore, the commitment to achieve quality and sustainability goals requires a high level of employee involvement, which Moretto supports with training and awareness campaigns.

Initiatives and actions that find their expression in the publication of the Sustainability Report with which the company undertakes a transparent and shared path, with the belief that sustainable development is an opportunity to strengthen its organisation, create value for all stakeholders and contribute to a better future for the planet.

The document is available for consultation on the company website in the "ABOUT US" section.

**Moretto S.p.A.**  
Via dell' Artigianato, 3 -  
35010 Massanzago (PD), Italy  
► [www.moretto.com](http://www.moretto.com)

# GWDS the Revolutionary Economic, Innovative and Safe Solution to Further Improve the Quality of Blow Molded Parts

*The wall thickness of blow molded articles is always the smallest at those locations where the stretching ratio is the greatest when blowing the parison into the final geometry of the article. This is at least true for small articles which have to be produced using a die that is smaller than 50 mm in diameter. As an example for small bottles the wall thickness is always the smallest at the bottom region perpendicular to the welding line. As at least a certain wall thickness is demanded to meet the required useful properties the flow channel gap of the die has to be increased to reach the aspired wall thickness. As a consequence the wall thickness at both ends of the welding line where no stretching occurs gets much bigger than it is intended and that it would be necessary. That affords more raw material, and it increases the energy consumption. Additionally it extends the cycle times, as the wall sections which are too big need to be cooled for a longer time. But this also limits the capacity of the blow molding machines and thus also the productivity of the company. For a long time it was not at all possible to alter the wall thickness over the circumference of the parison at a locally limited area for small blow molded articles while the parison is discharged.*

For greater die diameters the well established PWDS-solution can be used to alter the wall thickness over the circumference while the parison is extracted. But the PWDS-system is rather sophisticated and therefore extremely expensive. Furthermore the PWDS-system has to be maintained regularly as it possesses different devices, which might fail and cause machine break downs. In both cases this can not be avoided that in those times the machine is not available to produce parts. That is why for many articles it is even questionable whether there exists a reasonable relation between the necessary investment and the benefit that is reached. So for decades there was a need for a solution, which can be used for all blow molded articles independently whether they are small or big and independently what geometry they might have. And of course for a long time there was also an economic solution that costs a minimum of a PWDS-system, that needs no regular maintenance and that cannot cause non-operating steps.

## Comparison between rules to design conventional dies for blow molding and those for GWDS-dies

The general designing rules for dies for extrusion blow molding have been established in the last century and are still state of the art nowadays. They have not been put into question and thus kept unchanged. Most dies which are actually designed and offered for extru-

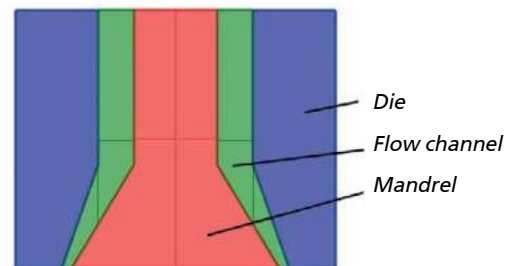

Picture 1: Cross section of a conventionally designed conical die

Profile not active  
Same velocity  
 $V=V$

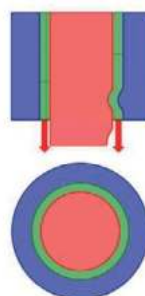

Profile active  
The velocity keeps unchanged  
 $V=V$

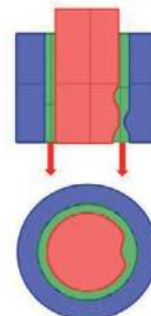

Picture 2: Cross sections of cylindrical GWDS-dies with different position of the mandrel in order to alter the wall thickness of the parison over its circumference in a locally limited way



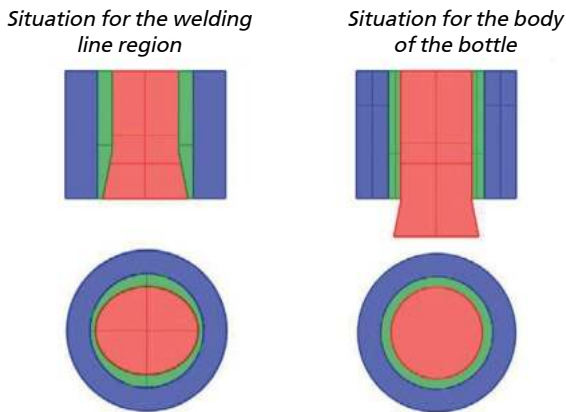

Picture 3: Cross sectional drawings of a GWDS-die designed for the production of round bottles

sion blow molding have still a conical flow channel. As well the die as also the mandrel are conical at their ends (Picture 1).

That helps to alter the wall thickness of the parison homogeneously over the complete circumference. Conventional conical dies are also well suited to compensate the elongation of the parison due to its increasing weight. But conventional conical dies are of extreme disadvantage in case you want to alter the wall thickness differently over the circumference of the parison. That is why it was necessary to break fundamentally with the traditional well established design strategies for dies to realize the patented (US 9,676,134 B2) GWDS-technology (Picture 2). It is the only available solution which can alter the wall thickness of the parison differently over its circumference while it is extracted that can be used universally. This because the GWDS-technology is not subject to limitations neither regarding the die diameters nor regarding of the individual geometry of the part. To enable to alter the wall thickness of the parison differently over its circumference the mandrel should be designed to be not conical but to be predominantly cylindrical at its end. Additionally the die should either be cylindrical at its end or converging with the smallest diameter at its end. Furthermore the diameter of the mandrel should be smaller than that of the die end.

### Advantage of GWDS designed dies

In this case the mandrel can be pushed out of the die without touching it. When this is done the end of the mandrel is no longer part of the flow channel so that the parison simply glides over the end region of the mandrel which is protruded from the die. Now the mandrel region which produces out of the die can be profiled in any shape that is necessary for a special region of the parison. As long as the protruded profiled mandrel end is outside of the die and thus not part of the flow channel the thickness of the parison is determined by the flow channel gap which exists at the end of the die. The wall thickness of the parison is not at all affected by the profiled end of the mandrel which is situated outside of the die. It simply glides over it without that the

wall thickness which is built by the gap at the die end is not influenced or modified by the profiled end region of the mandrel. This because it is no longer part of the flow channel. But when the part of the parison is discharged that needs the variation in the thickness over the circumference of the parison the mandrel is simply pulled up so that the profiled end region becomes part of the flow channel. Then the thickness of the parison varies over the circumference. This according to the changing flow channel gap which then exists at the die end (see Picture 2).

The mandrel for instance is designed to be oval at its end for a simple round bottle. This is necessary to equalize the wall thicknesses of the bottle at both ends of the weld line and perpendicular to the weld line. But that oval shape is not at all suited for the upper part of the bottle. Therefore the oval end geometry of the mandrel is continuously converted into a round geometry over a short length. Now when the part of the parison is discharged which is responsible for the weld line region of the blown article the oval end of the mandrel matches with the end of the die. The more the influence of the weld line vanishes the more the mandrel is pushed out of the die until the round geometry matches with the end of the die. This round mandrel geometry is then responsible for the parison thickness which is necessary for the rest of the bottle (Picture 3)

Thus the GWDS-technology can be easily retrofitted to every existing blow molding head. It neither affords a deformable die nor special actuators. It can be used with every existing blow molding machine without that the machine has to be modified in any way. Only the die of the head has to be exchanged. Although it needs only a solid die and a solid mandrel it enables to alter the wall thickness differently over the circumference of the parison while it is discharged. Without exception every blow molded article that is nowadays produced can be further improved in its quality in a very effective way using the GWDS-technology. The flow channel gap at the exit of the die can be easily altered by time matching the varying draw ratios which exist for different locations of the part to be produced. A GWDS-die and mandrel do not need to be maintained in regular time intervals and they can not be responsible for potential machine break downs. This because a solid die and a solid mandrel cannot fail during operation. In case a head is immediately equipped with a GWDS-die the fabrication cost of the head is comparable with that of a head which is equipped with a conventional conical die.

### The economic value of the GWDS-technology

The GWDS-technology is a solution which cuts the cost to establish a dynamic radial wall thickness programming nearly to zero in comparison with the state of the art expensive PWDS-system. It helps to further improve the quality of blow molded articles. But in the same time it saves raw material, reduces the energy consumption, cuts manpower requirements in the production, increases the capacity of the machines and thus increases



Picture 4: Articles that have been produced with a conventional conical die and with a predominantly cylindrical GWDS-die

the productivity. This due to the fact that it cuts the cycle time when avoiding thick wall regions in the part. As a consequence more articles can be produced per unit of time. Every existing head can be easily retrofitted with a solid GWDS-die and a solid GWDS-mandrel by only exchanging the existing conventional die and mandrel. So it is very inexpensive to retrofit an existing head. As a consequence extreme short times can be reached until the investment is paid back and significant improvements of the rate of return can be reached. Picture 4 compares the wall thickness distributions, the weight and the cycle times achieved when producing four different articles with a conventional conical die and alternatively with a predominantly cylindrical GWDS-die.

For over a decade in Europe nobody dares to replace a head that was equipped with a PWDS-system by a GWDS-die. Now an Asian blow molding machines producer of all companies dared to substitute his Asian copy



4b: Using the following QR-codes short video can be seen which show the discharge of the parison for the part on top (left) and for the part shown on the bottom (right)

of a PWDS-system by a GWDS-die. The company was forced to do that as the customer did not accept to pay for the ordered machine as they claimed that the weight of the 20 liter cans which were produced were too high. That is why the company decided to dismantle the Asian copy of a PWDS-system and to attach a solid GWDS-die and a solid mandrel (Picture 5). The company managed it to further reduce the weight of the cans by 5 %. In Europe some few producers of blow molded articles have already successfully replaced their conventional conical dies by GWDS-dies in order to further improve the quality of their parts. The quality was improved and the weight of the articles and the cycle time were reduced. But for what reason ever still no European machine producer has decided yet to design and to offer predominantly cylindrical GWDS-dies to their potential customers.

*Dr.-Ing Heinz Groß*

Dr.-Ing. Heinz Groß Kunststoff-Verfahrenstechnik  
Ringstr. 137, 64380 Roßdorf, Germany  
➔ [www.gross-k.de](http://www.gross-k.de)

Picture 5: Components of the Asian copy of a PWDS-system that has been dismantled from the head (left side) and GWDS-die and GWDS-mandrel that have been attached to the head instead (right side)

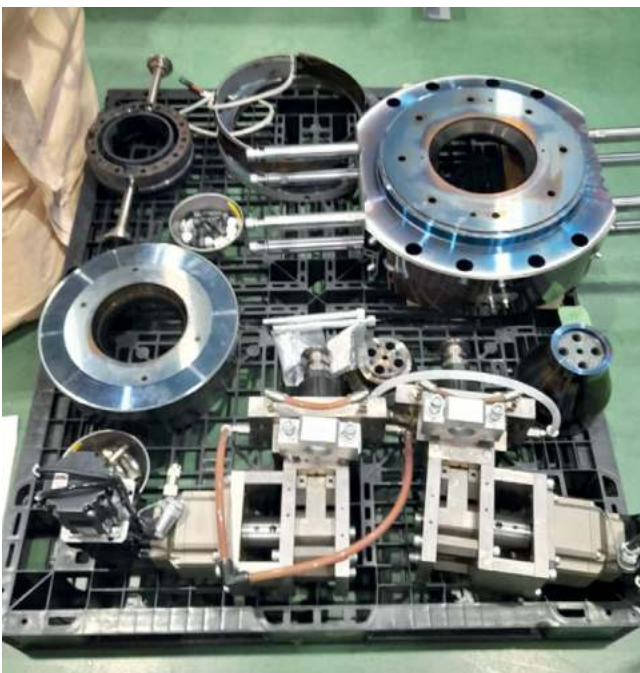



# Corporation and the Really Big Thing – *Contract Conclusion for a New Stretching Line for Ultra-Thick Simultaneously Stretched Film Applications*

*Japanese FP Corporation (FPCO), a leading manufacturer of food containers, has made a groundbreaking advancement in film technology with the development of the world's first ultra-high-rigidity biaxially oriented polypropylene (OPP) sheet. This innovation is the result of a collaboration with many different companies and Brückner Maschinenbau with their advanced film stretching technology – and has now culminated in a contract for a new stretching line.*

Over the past 10 years, FPCO has conducted extensive research and testing at Brückner's technology center and pilot line. This partnership has optimized FP Corporation's material as well as Brückner's simultaneous stretching technology LISIM® to produce high-class thick BOPP films for a variety of applications, ranging from food containers to industrial uses such as for the automotive industry.

## **The world's first ultra-high-rigidity biaxially oriented polypropylene sheet for various applications**

The new BOPP sheet has pioneered a new category of food tray used for "frozen to microwave" due to superior cold & heat resistance. Namely, meeting the growing demand of frozen foods in the field of food trays, the newly developed BOPP sheet can be used for production of a food tray for frozen food and can also be used for microwave oven cooking as it is.

Industrial applications and home furnishings:

- Inherent characteristics as PP: Light weight, chemical resistance, recyclability



*Yoshihisa Saito (Assistant to the Executive General Manager); Hiroshi Ogawa (Executive Vice President and Director, Executive General Manager of Global Trading Division), both FP Corporation; Boris Pasternack (Head of Sales East Asia); Hosoya Hiroyuki (Senior Sales Representative), both Brückner Maschinenbau*

- Characteristics from biaxial stretching: Transparency & high gloss, high rigidity & toughness, cold resistance

- Remarkable characteristics: Excellent formability, decorativeness, mono-material

The new OPP sheet with a thickness of 150 to 300 micron, exhibits

excellent mechanical features such as high rigidity and high toughness, when utilized as a sheet for "In-Mold Labeling" (IML), rigidity and toughness of the molded article can be significantly enhanced. Therefore, compared to a conventional IML article, the amount of injection resin can be decreased to

20% by mass in order to attain the same level of mechanical strength of the conventional IML article. Moreover, if the sheet is decorated with printings on injection side, it can be produced a decorated IML article that contributes to paint-free system. This makes the IML article suitable for automobile parts and other industrial parts, and this advancement contributes to reducing environmental impact.

### A laminated OPP sheet

**Features:** High rigidity, impact resistance, toughness, light weight, thermo-formable, and excellent decorative properties due to superior transparency

**Applications:** Automotive, home furnishings, solar cells, and as a partial replacement for materials like steel, aluminum, and carbon-fiber-reinforced plastics

The laminated OPP sheet with a thickness of 1 to 3 mm is suitable as building material, including windows, waist-high walls, carport roofs and solar panels, supporting materials due to its transparency, mechanical strength, and light weight. Furthermore, when arranged as a decorated sheet, it can be used in several fields such as automobile exterior, automobile interior, housing & furnishings. In par-



*Cars side mirror*

ticular, when used as exterior material for automobile, it also enables paint-free system, and significantly contributes to the reduction of environment impact.

Boris Pasternack, Brückner Maschinenbau's Head of Sales East Asia says: "After more than 10 years of intensive collaboration with FP Corporation, we are thrilled to see this innovative development move into production – a remarkable example of German-Japanese partnership and pioneering spirit."

Yoshihiro Nishie, FP Corporation's General Manager of Comprehensive Research Institute and Basic Technical Engineering Dept. adds: "Over a decade since the commencement of foundational research, the world's first BOPP sheet technology has been successfully developed, thanks to a fruitful partnership with Brückner. This achievement can be attributed to the culmination of both companies' technical expertise."

#### *Future Prospects:*

The new OPP sheets have already received positive recognition across various industrial fields. FP Corporation is currently designing a new plant to start production in late 2027, with plans to market these products through alliances with related industries. This collaboration not only highlights the innovative capabilities of both companies but also sets a new standard for sustainable and high-performance materials in the industry.

Brückner Maschinenbau GmbH

➔ [www.brueckner.com](http://www.brueckner.com)

*Food tray*





# SMART EXTRUSION

**THE SPECIALIZED WEBPORTAL  
ON EXTRUSION  
FOR EVERY MODERN NEED**



**VM** Verlag GmbH  
Cologne, Germany



[www.smart-extrusion.com](http://www.smart-extrusion.com)

# Chinaplas



Transformation ·  
Collaboration ·  
Sustainability



Shenzhen,  
PR China

Shenzhen World Exhibition &  
Convention Center (Bao'an)



20  
25

4·15  
/  
4·18



CHINAPLAS

Hong Kong (852) 2811 8897 | Singapore (65) 6631 8955 | (852) 6217 0885

Chinaplas.PR@adsale.com.hk | www.adsale.com.hk | www.ChinaplasOnline.com

Pre-register Now



Organizer



Co-organizer



Sponsor



O2O Strategy Partner



Official Online Media

